

TRIGANO

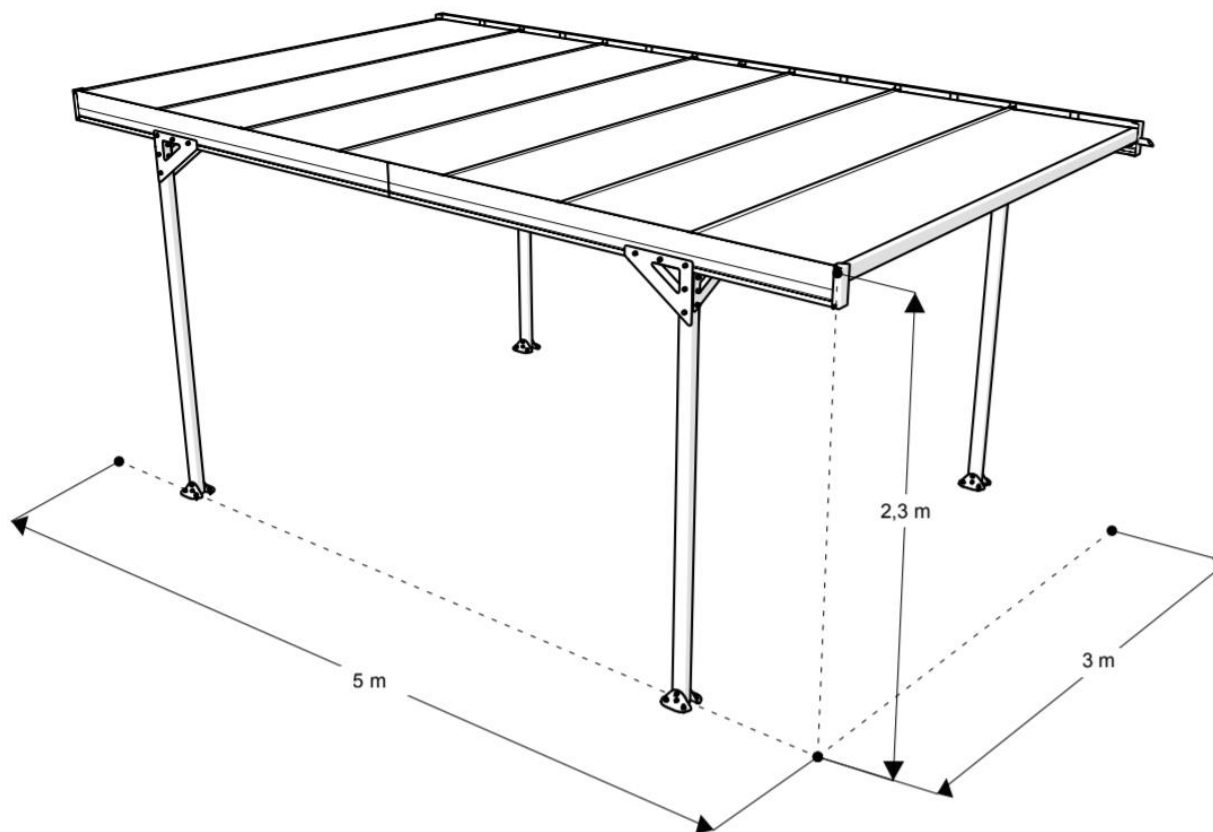

Návod na použitie: Prístrešok na auto Trigano Mistral

kód: 7517

SK

Vážené zákazníčky, vážení zákazníci

Teší nás, že ste sa rozhodli pre prístrešok na auto **Trigano**. Pred poskladaním prístrešku na auto si pozorne prečítajte návod na použitie. Prístrešok na auto používajte iba tak ako je to popísané v tomto návode na použitie.

Váš **DUVLAN** tím

Záruka

Predávajúci poskytuje na tento výrobok 2-ročnú záruku.

Záruka sa nevzťahuje na škody spôsobené nesprávnou montážou, nesprávnou údržbou, mechanickým poškodením, opotrebením dielov pri bežnom používaní, neodvratnou udalosťou, neodbornými zásahmi, nesprávnym zaobchádzaním, či nevhodným umiestnením. V prípade reklamácie nás kontaktujte.

Záručná doba začína plynúť dátumom predaja (uschovajte preto doklad o kúpe).

Zákaznícky servis

Aby sme Vám mohli čo najlepšie pomôcť s prípadnými problémami na Vašom prístrešku na auto, poznačte si presný názov výrobku.

Pokyny pre zaobchádzanie so zariadením po vyradení z prevádzky

Zariadenie **Trigano** je recyklovateľné. Prosíme Vás, aby ste Vaše zariadenie po skončení životnosti odovzdali do zberní odpadu (alebo miesta na to určeného).

Kontakt

Duvlan s.r.o.
K Zornici 1990/23
957 01 Bánovce nad Bebravou
e-mail: servis@duvlan.com
web: www.duvlan.com

Pokyny

Tento návod na použitie je len referencia pre zákazníkov. **DUVLAN** nepreberá ručenie za chyby vzniknuté prekladom alebo technickou zmenou produktu.

Bezpečnostné upozornenie

1. Pred začatím montáže si pozorne prečítajte manuál.
2. Kroky vykonávajte opatrne a v poradí uvedenom v tomto manuáli.
3. Uschovajte si tieto pokyny na bezpečnom mieste počas celej životnosti prístrešku.
4. Maximálna odolnosť voči vetru: 90 km/h.
5. Maximálna odolnosť voči snehu: 10 cm.
6. Diely roztriedte a pred zložením ich porovnajte so zoznamom dielov.
7. Z bezpečnostných dôvodov odporúčame, aby tento výrobok montovali najmenej dve osoby.
8. Niektoré časti majú ostré kovové hrany. S týmito časťami zaobchádzajte opatrne a pri montáži vždy noste rukavice.
9. Nepokúšajte sa zostaviť výrobok vo veternom alebo vlhkom prostredí.
10. Plastové vrecká uchovávajte vždy mimo dosahu detí.
11. Udržujte deti mimo dosahu montážnej oblasti.
12. Nepokúšajte sa montovať prístrešok na auto, ak ste unavení, užívali ste lieky, ste pod vplyvom alkoholu alebo ak máte sklony k závratom.
13. Pri používaní rebríka alebo elektrického náradia sa uistite, že dodržiavate bezpečnostné pokyny výrobcu.
14. Nešplhajte ani nestojte na streche.
15. Tento produkt bol navrhnutý a vyrobený len na použitie ako prístrešok na auto.
16. Po zmontovaní prístrešku na auto bezpečne utiahnite všetky skrutky.

Montáž

- Obráťte sa na miestne stavebné úrady a zistite, či je na postavenie prístrešku na auto vo vašej oblasti potrebné stavebné povolenie.
- Prístrešok na auto musí byť inštalovaný na rovnom, vyrovnanom teréne, aby sa zabezpečila stabilita a zabránilo sa riziku zrútenia konštrukcie.
- Prístrešok na auto musí byť ukotvený k zemi, aby sa zabezpečila stabilita a pevnosť konštrukcie a aby sa zabezpečilo krytie záruky.
- Počas montáže umiestnite pod diely, ako je obal produktu, mäkký povrch, aby ste predišli poškriabaniu a poškodeniu.
- Vyberte miesto chránené pred prevládajúcimi vetrom a hromadením snehu (strechy, stromy...).
- Tento prístrešok pre auto musí byť namontovaný na pevnom podklade (ako je betón alebo asfalt).
- **Položenie podkladu:** Celkové požadované množstvo betónu je 0,25 m³.

- **Krok 16:** Utiahnite matice, aby ste udržali koľajnice na mieste.
- **Krok 18:** Odstráňte ochrannú fóliu a umiestnite ventilačnú pásku pozdĺž otvorených koncov polykarbonátových strešných panelov.
- **Krok 18:** Nainštalujte polykarbonátové strešné panely tak, aby strana proti UV žiareniu smerovala nahor k slnku. Táto strana je označená ochrannou potlačenou fóliou.
- **Krok 22:** Nainštalujte odkvapové rúry smerom nadol.
- **Kroky 23 a 24:** Na zdvihnutie strechy sú potrebné 4 osoby.
- **Ukotvenie:** Prístrešok na auto pripevnite k zemi nasledovne:
 - Do betónovej základne vyvrtajte otvory Ø8 pre každý z otvorov na podopretie stĺpikov.
 - Do otvorov zatlačte kotviace kolíky J-121374.
 - Upevnite kotviace kolíky.

Údržba

- Tento prístrešok na auto nie je strešnou konštrukciou, nelezte naň.
- Vždy udržiajte strechu a odkvapy čisté od snehu, nečistôt a lístia.
- Veľké množstvo snehu môže poškodiť prístrešok na auto a urobiť ho nebezpečným.
- Na čistenie prístrešku pre auto a najmä strešných panelov vždy používajte čistú vodu alebo jemné čistiace roztoky s neutrálnym pH.
- RAL kód farby: 7016.
- Upevnenie skrutiek je potrebné pravidelne kontrolovať.

Zoznam dielov

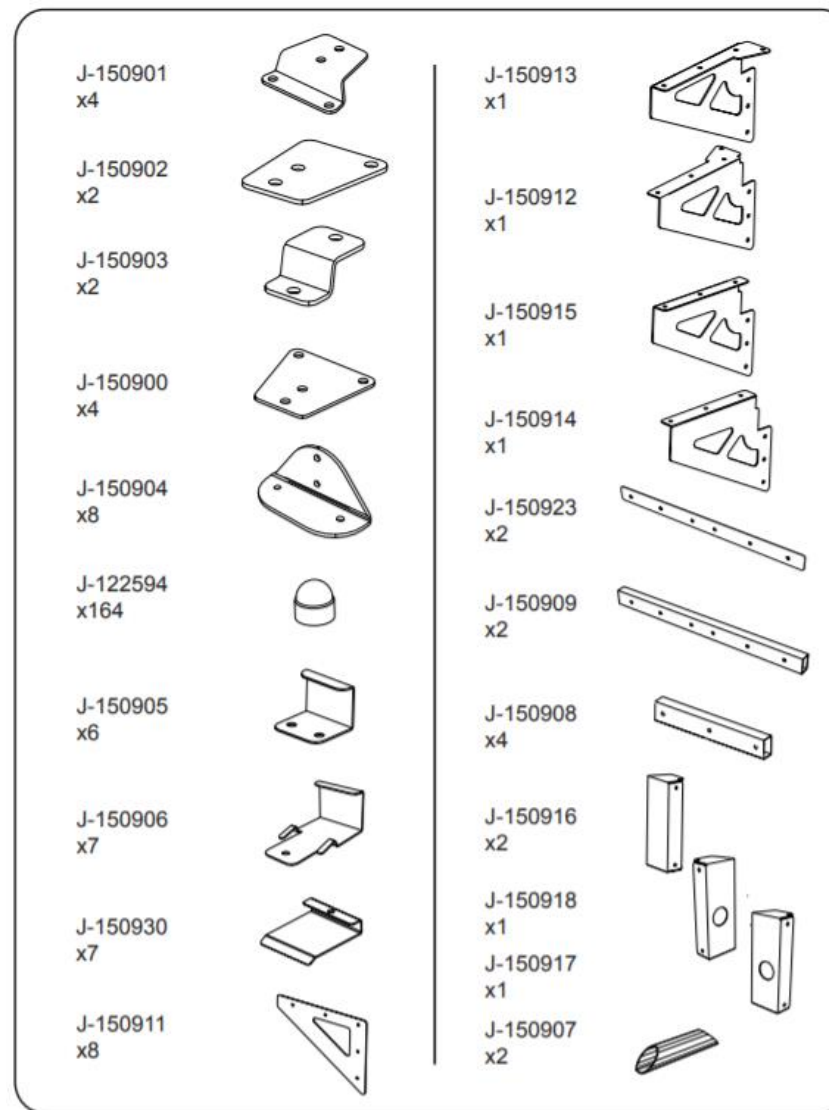
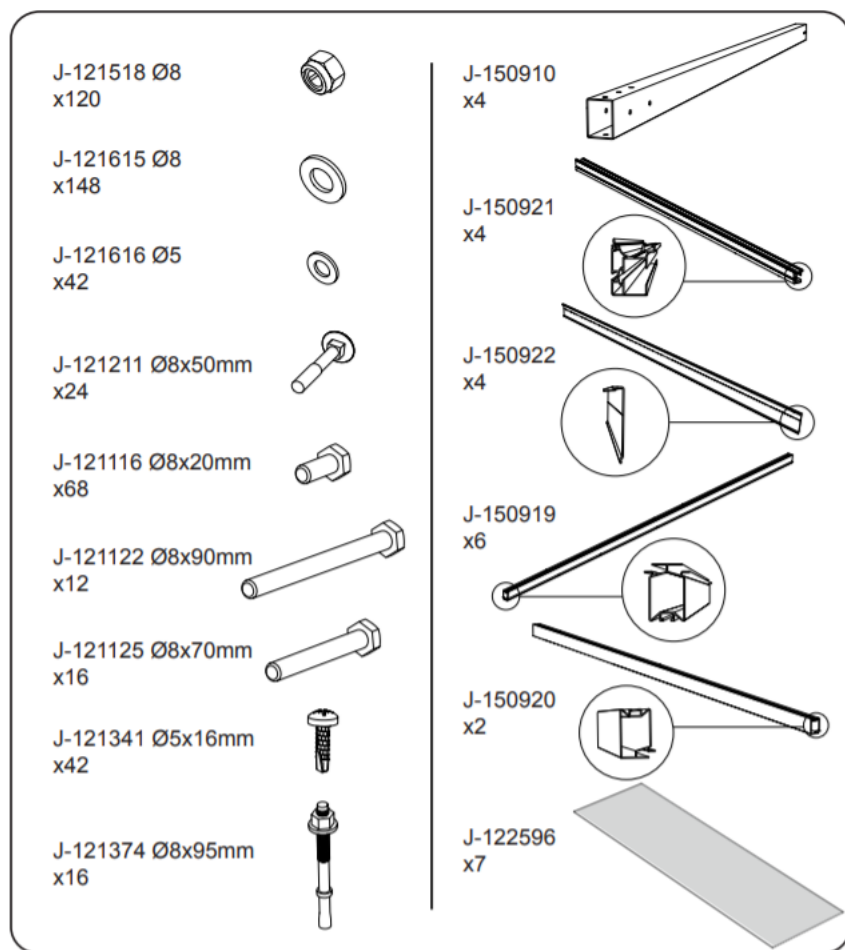

Náradie a pomôcky



Položenie základu

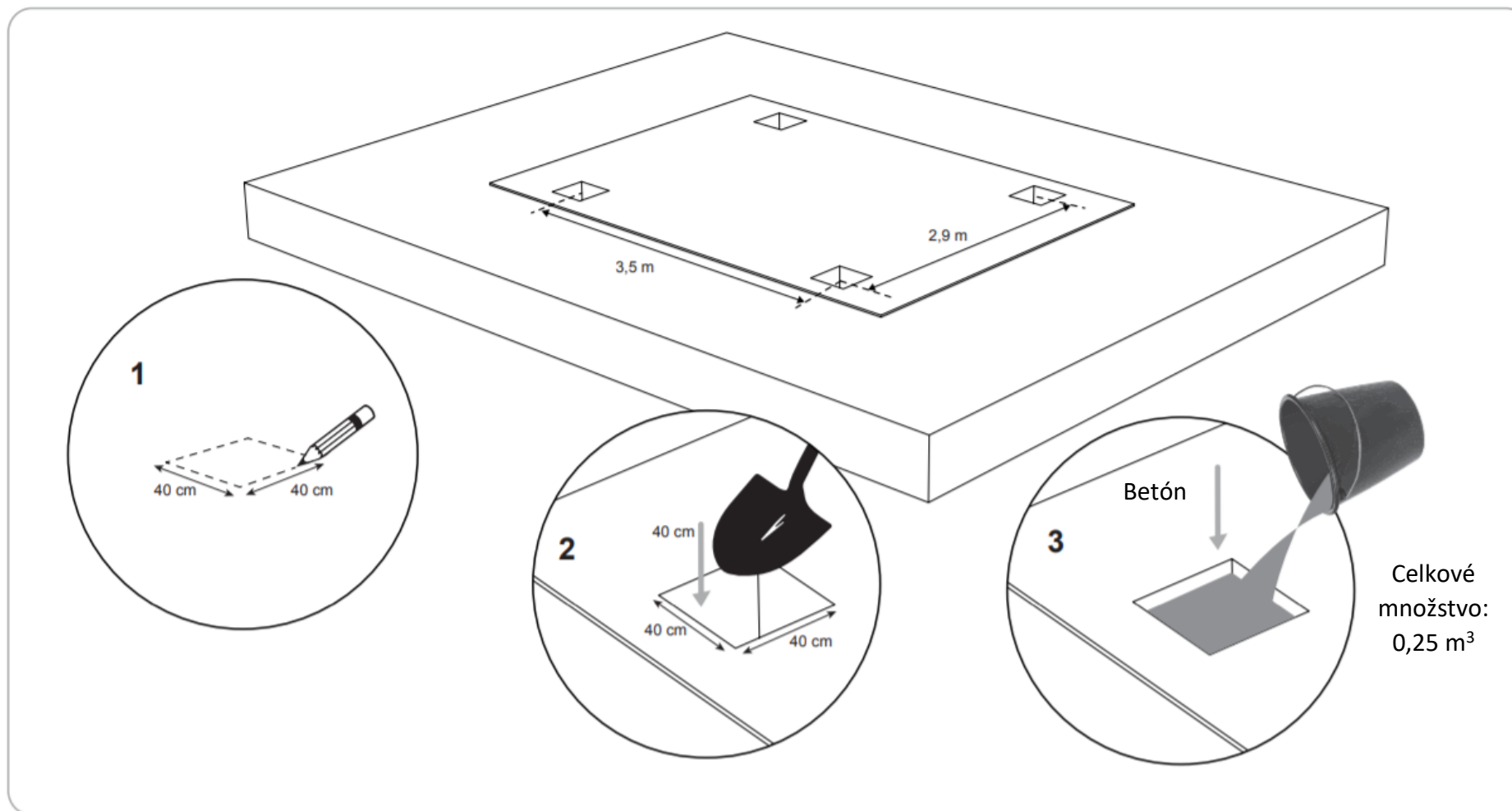

1

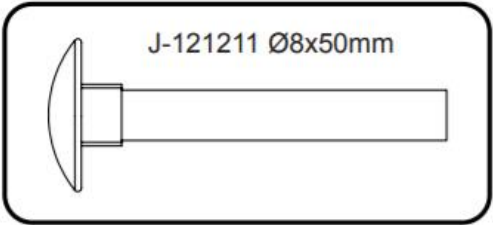

J-121518



x12

J-121615 Ø8



x12

J-121211



x12

J-150923

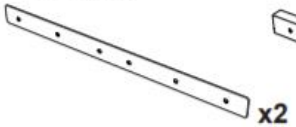

x2

J-150909

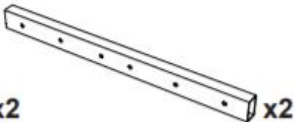

x2

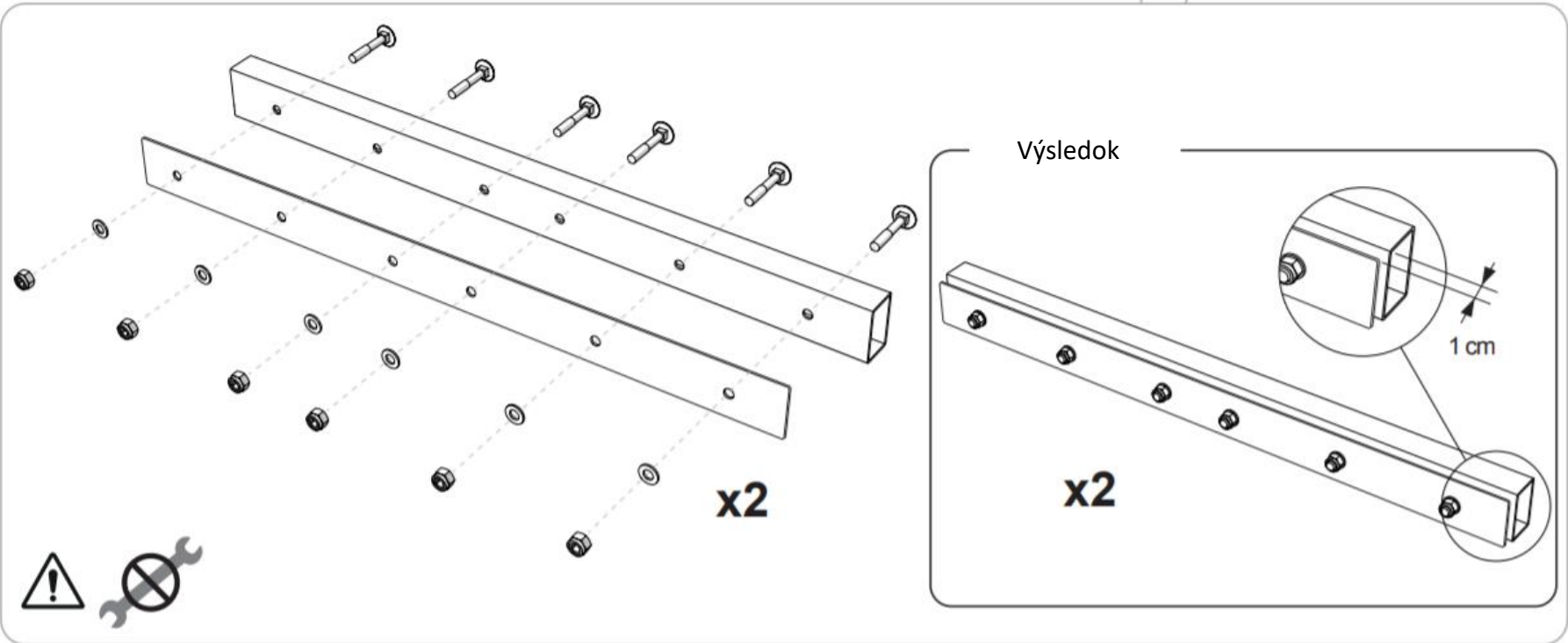

Výsledok

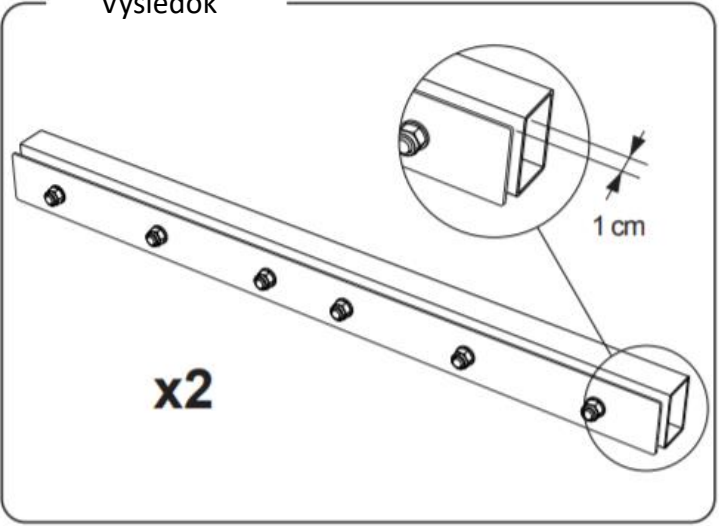

2

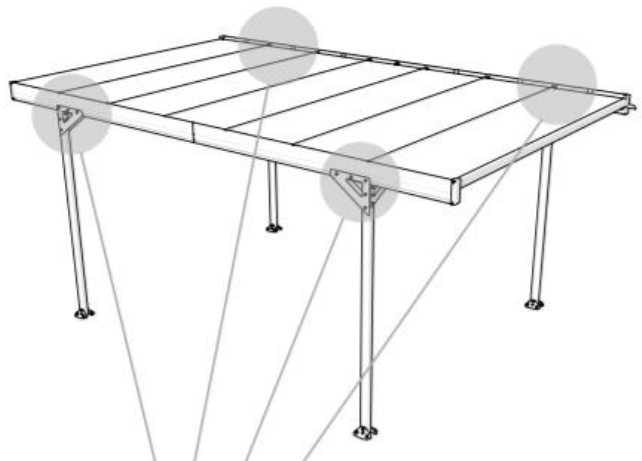
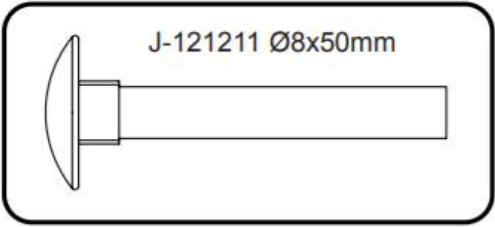

J-121518



x12

J-121615 Ø8



x12

J-121211



x12

J-150908

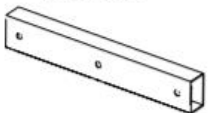

x4

J-150911

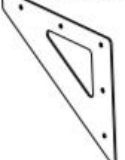

x4

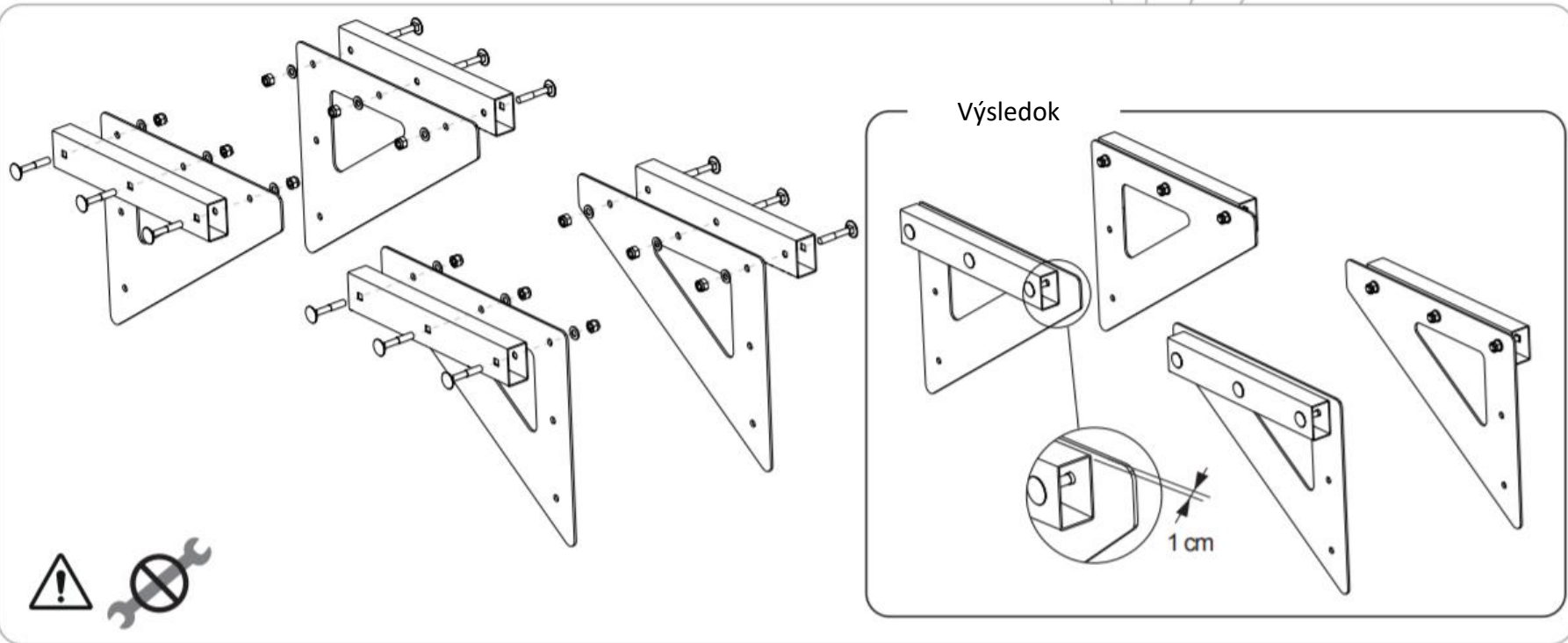

3

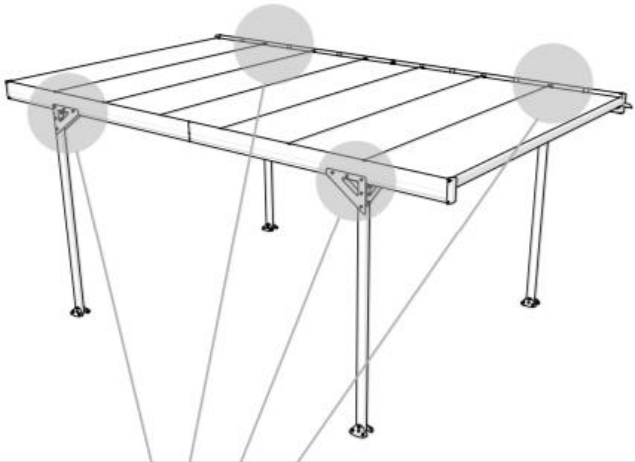
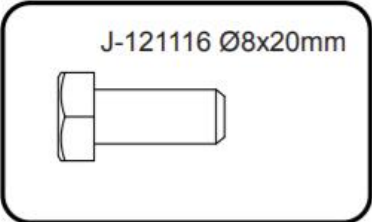

J-121518



x12

J-121615 Ø8



x12

J-121116



x12

J-150911

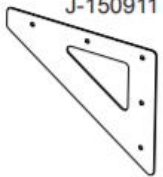

x4

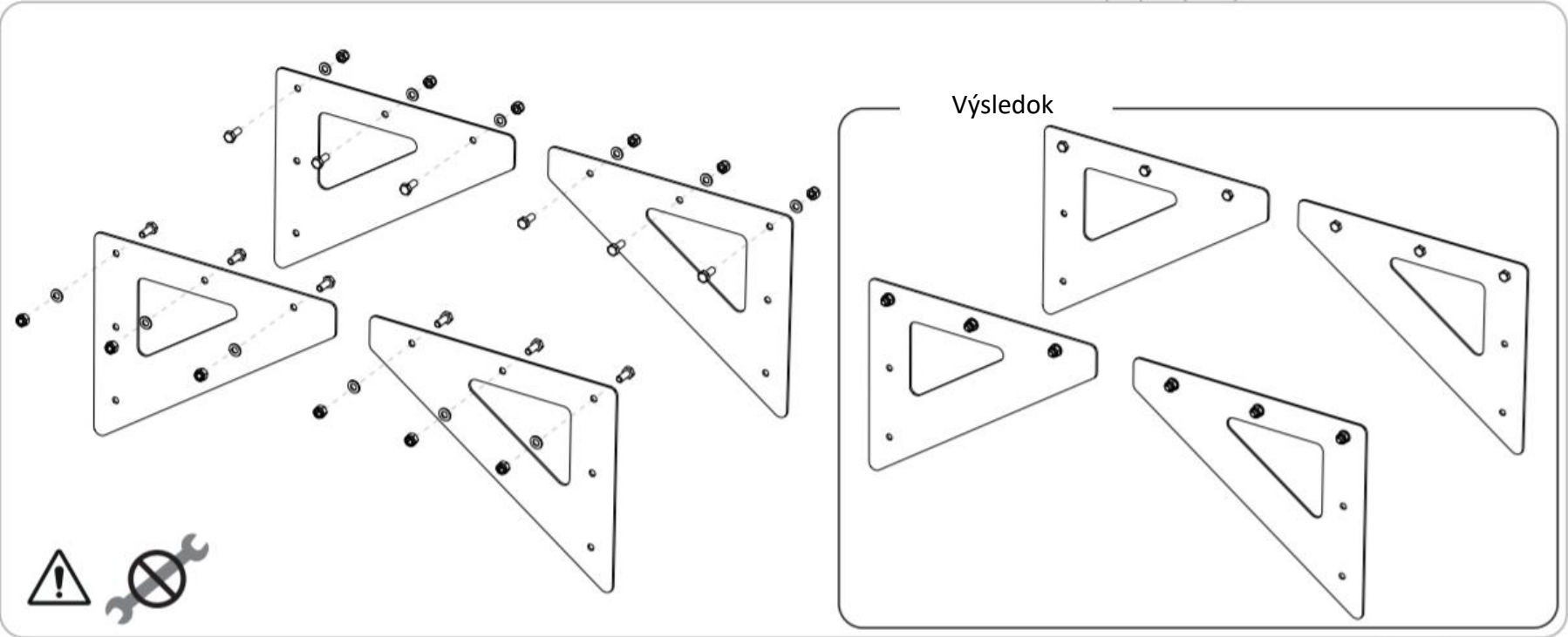

4

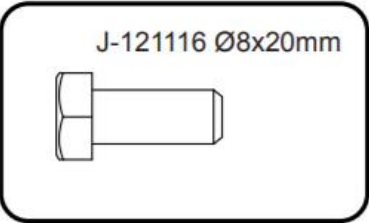

J-121518



x8

J-121615 Ø8



x8

J-121116



x8

J-150913

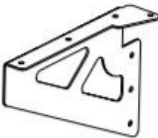

x1

J-150912



x1

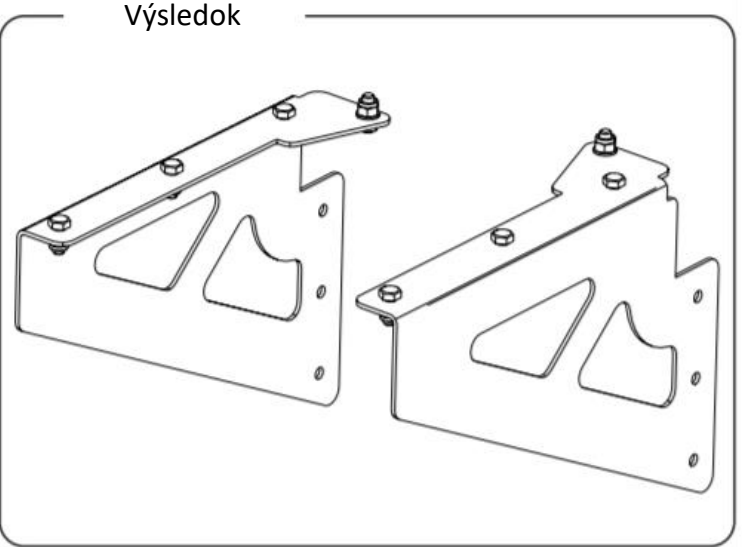
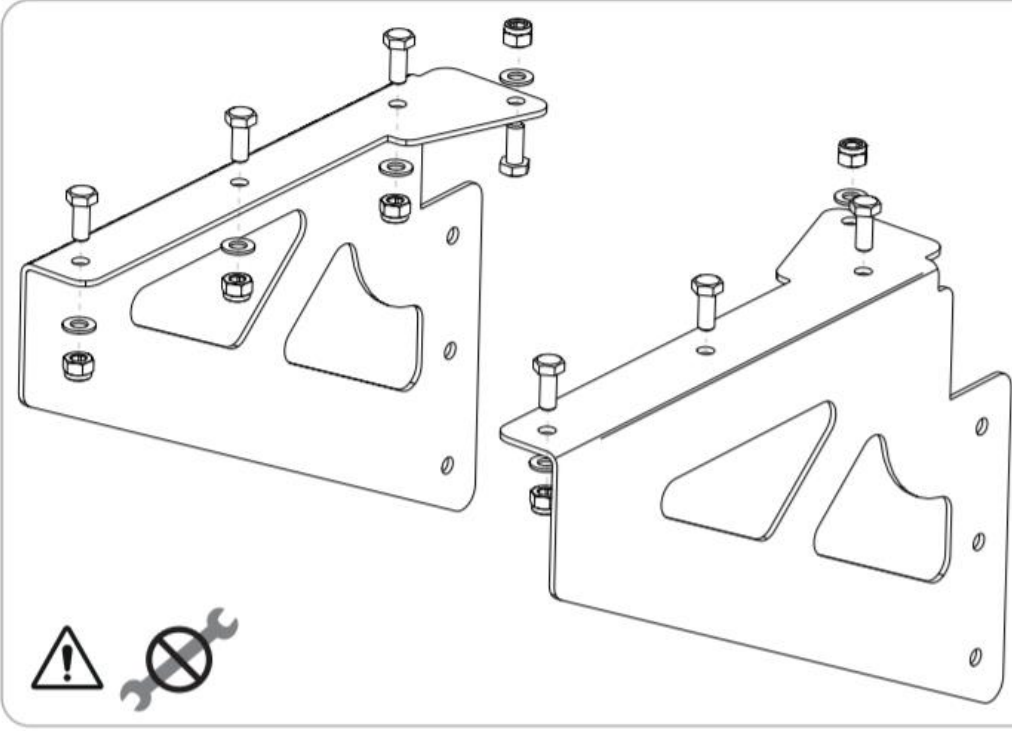
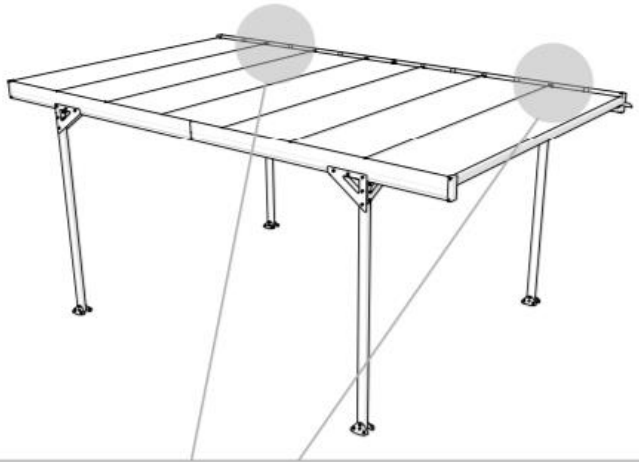

5

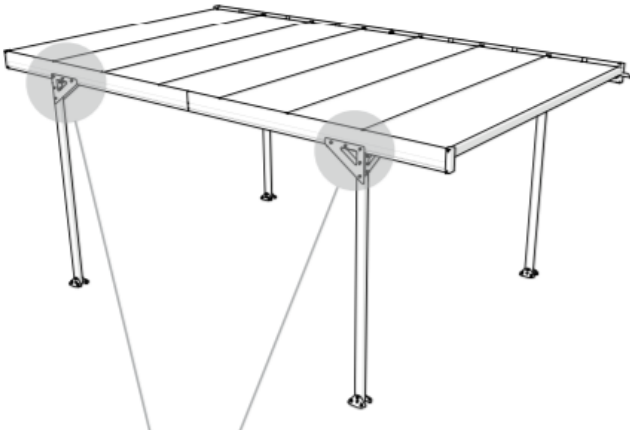
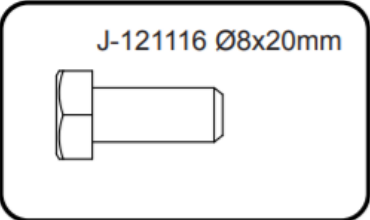

J-121518



x6

J-121615 Ø8



x6

J-121116



x6

J-150915



x1

J-150914

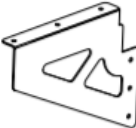

x1

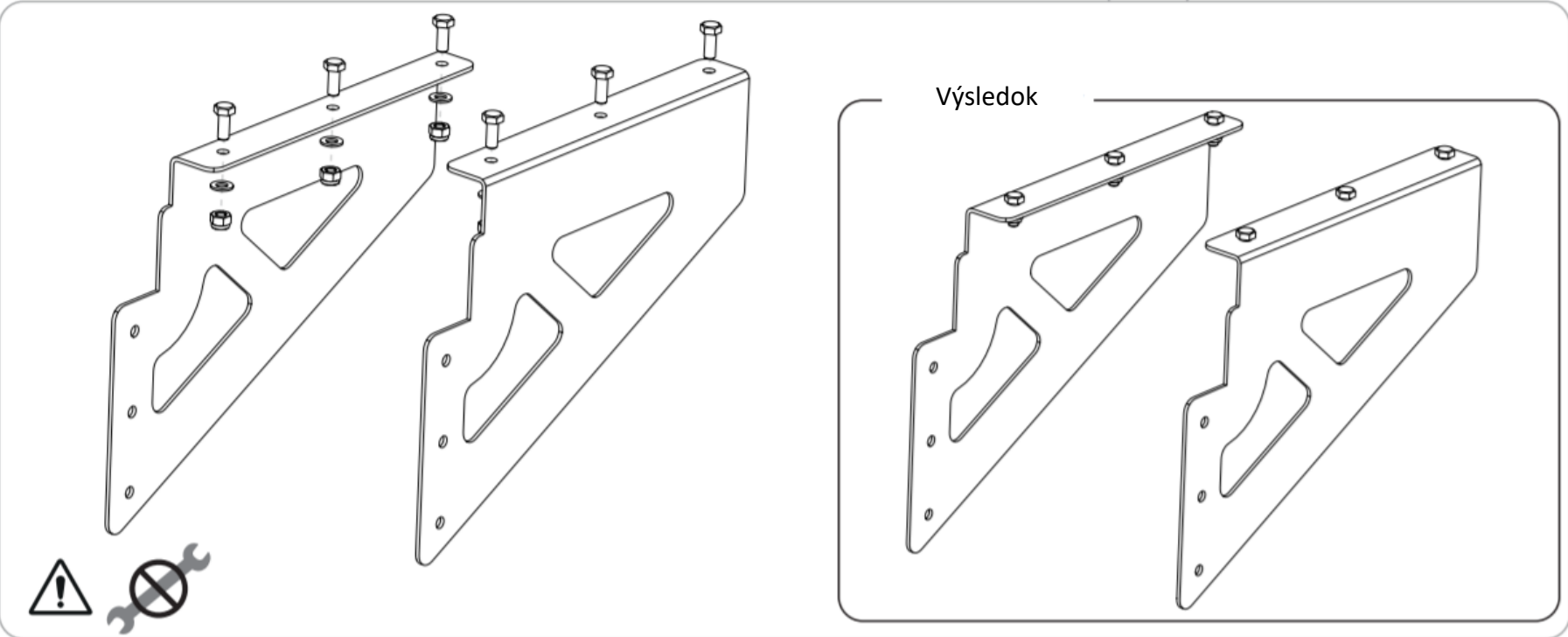

6

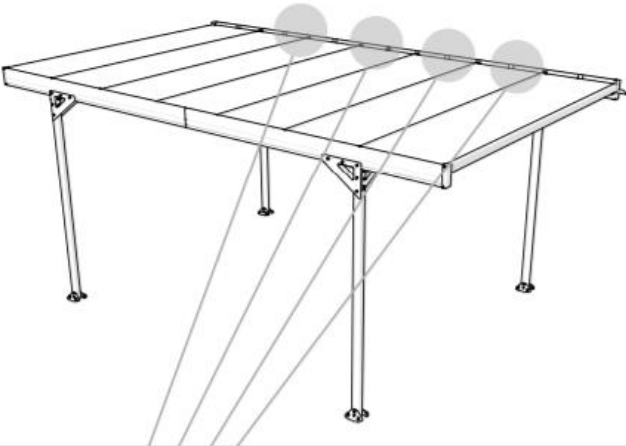
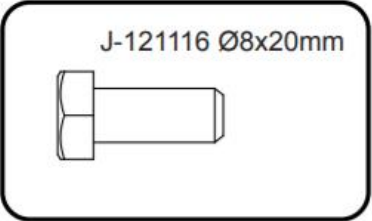

J-121518



x16

J-121615 Ø8



x16

J-121116



x16

J-150900



x4

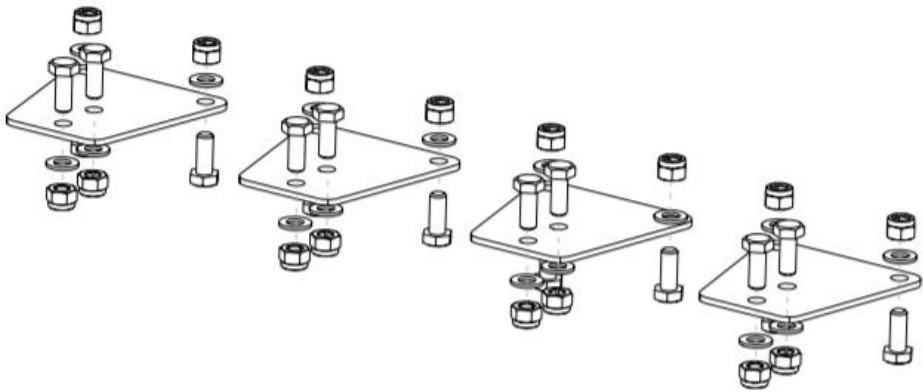

Výsledok

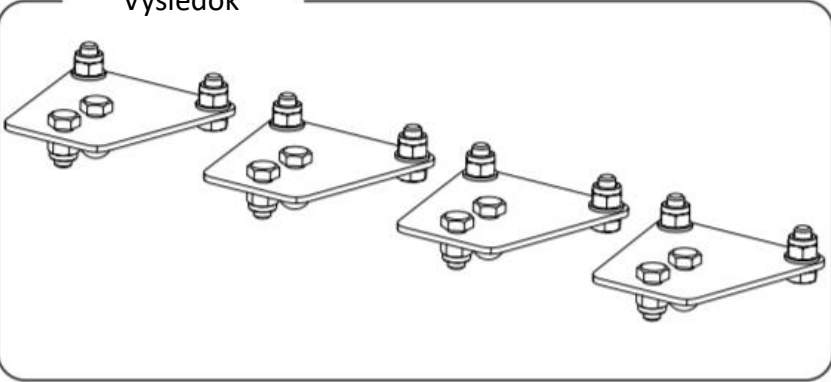

7

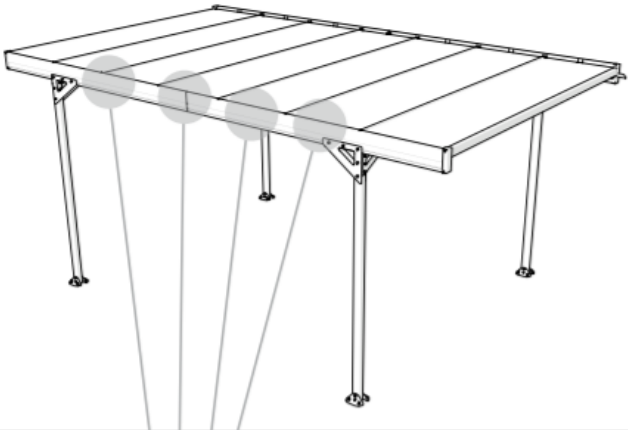
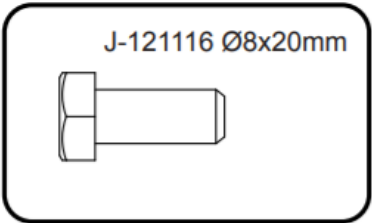

J-121518



x16

J-121615 Ø8



x16

J-121116



x16

J-150901

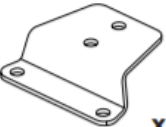

x4

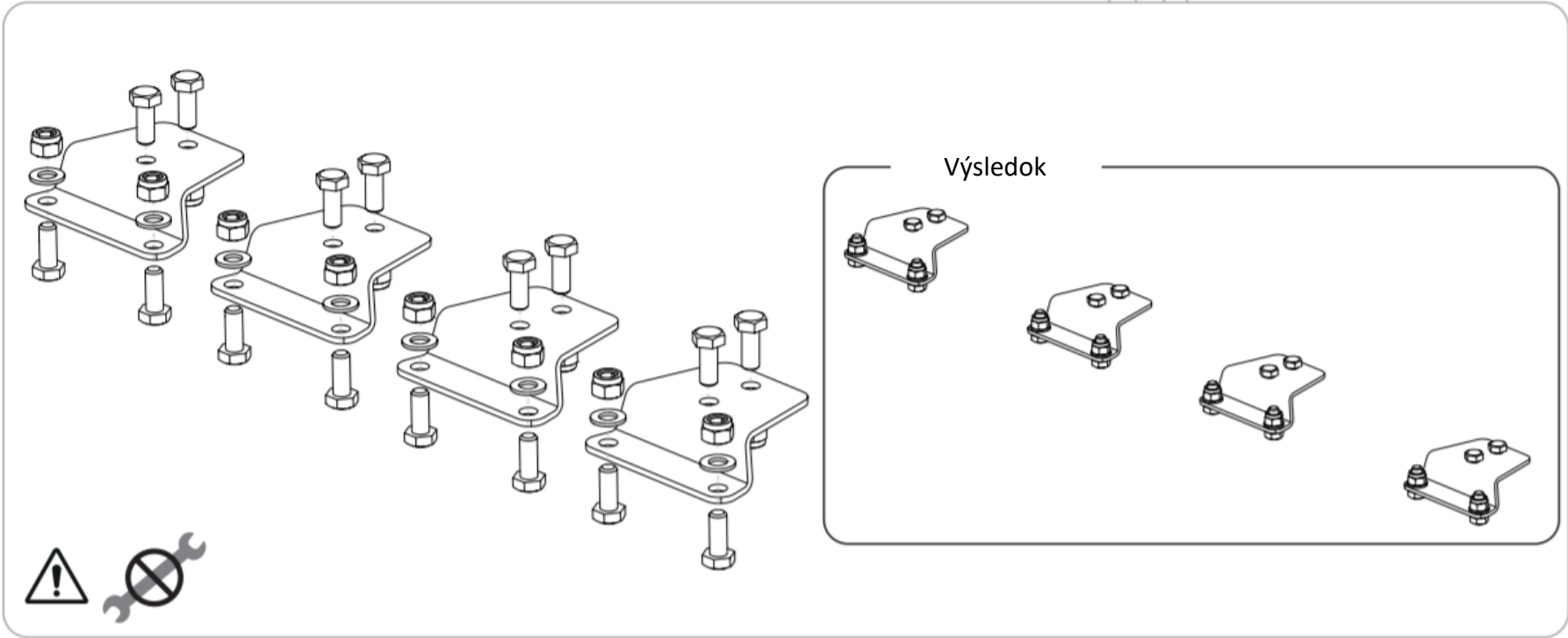

8

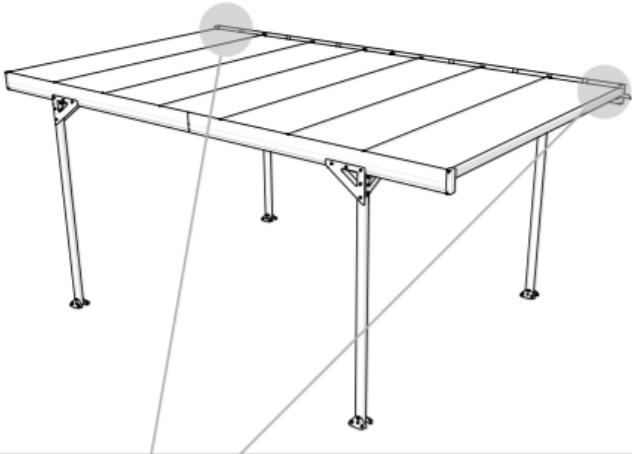
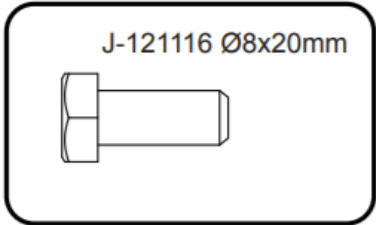

J-121518



x6

J-121615 Ø8



x6

J-121116



x6

J-150902



x2

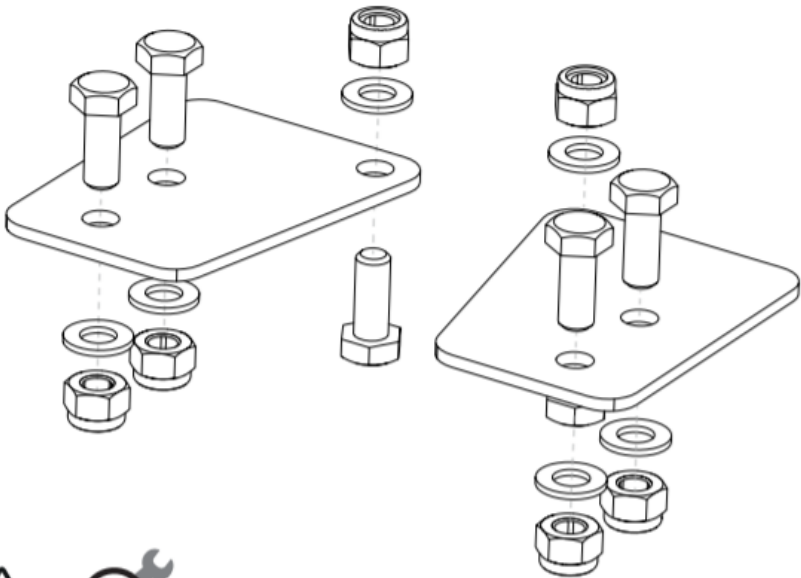

Výsledok

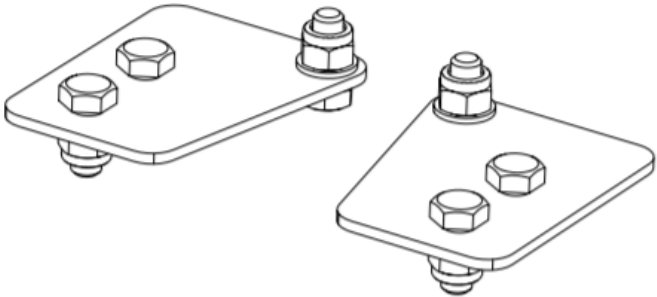

9

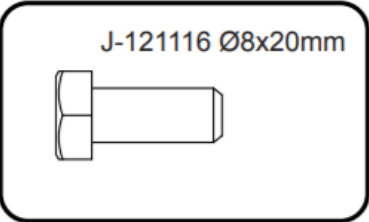

J-121518



x4

J-121615 Ø8



x4

J-121116



x4

J-150903



x2

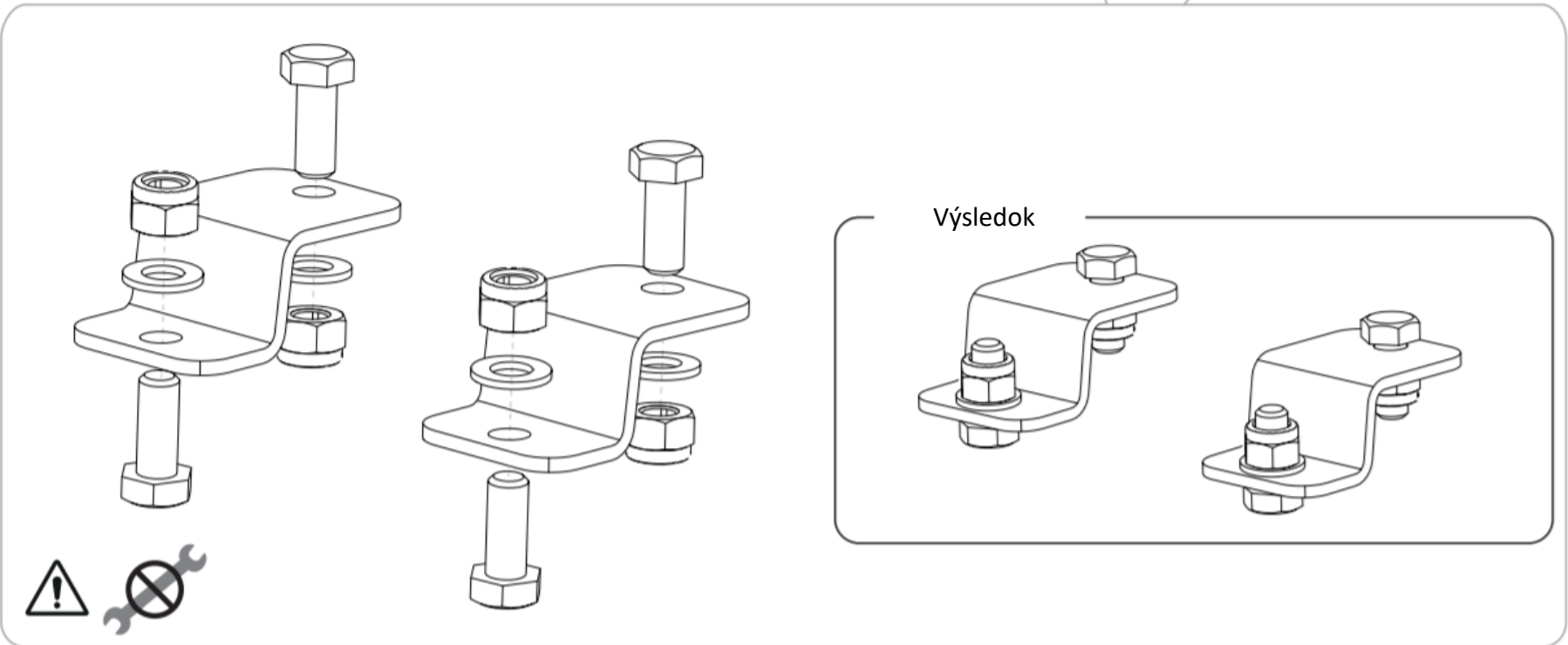
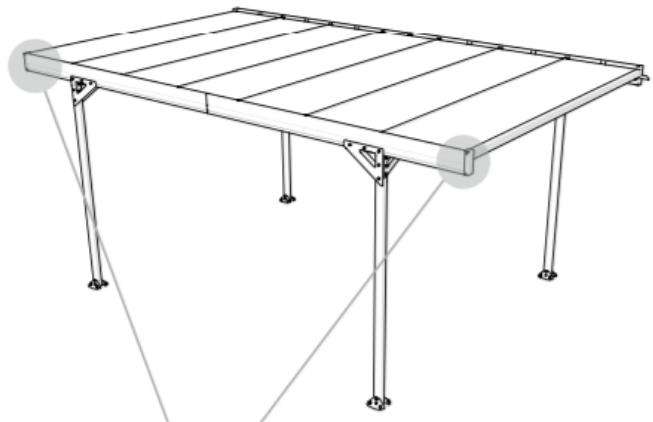

10

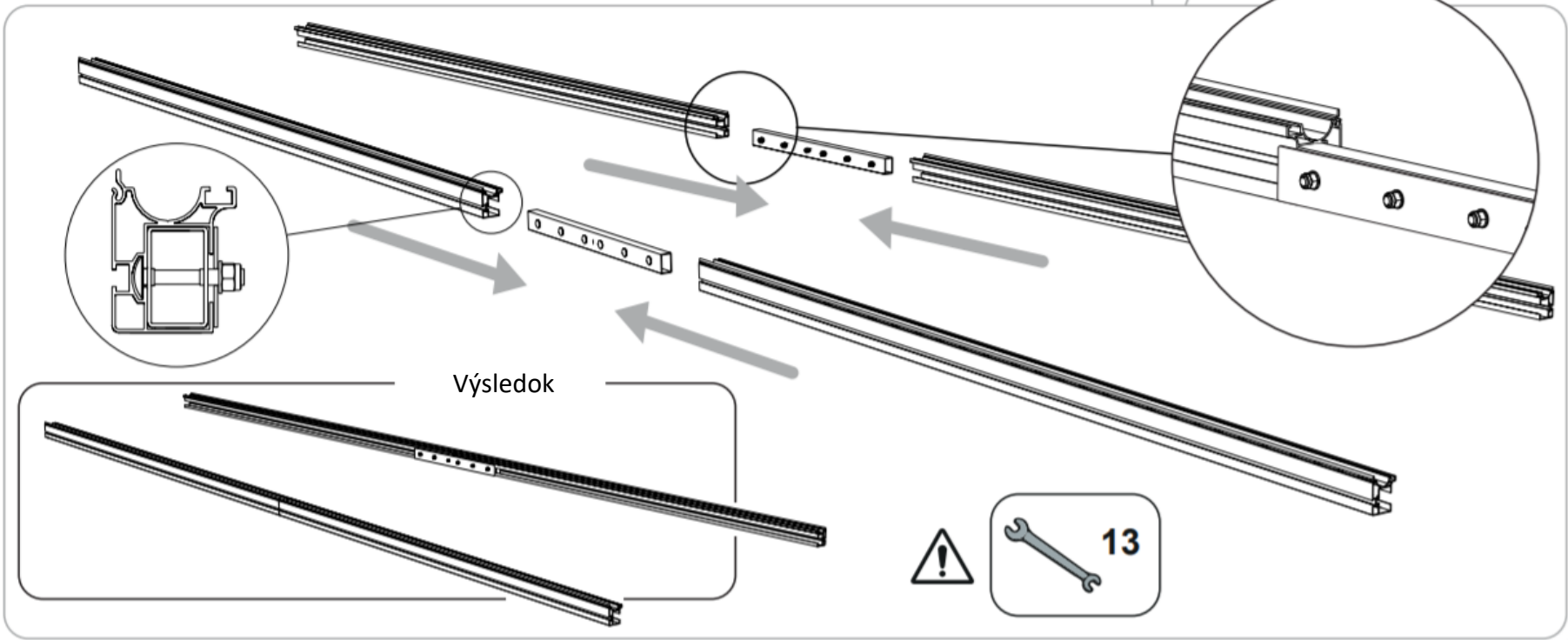
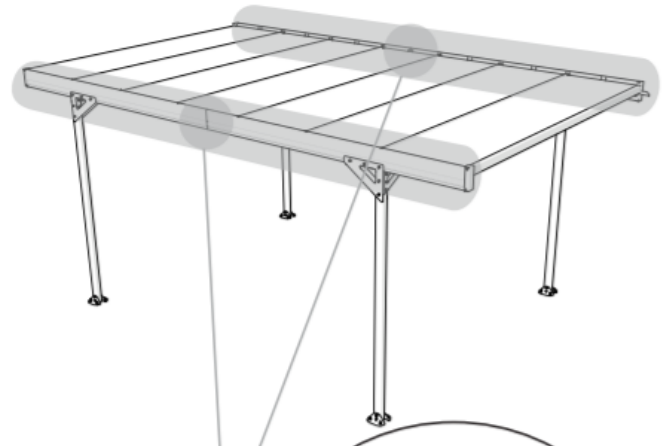
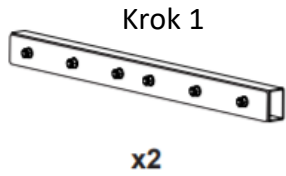
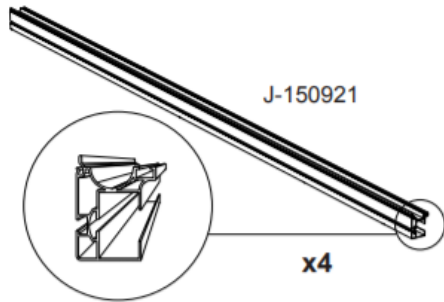

11

Krok 2

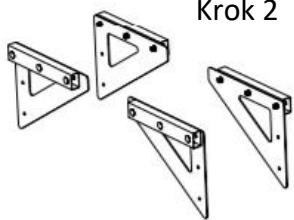

Krok 3

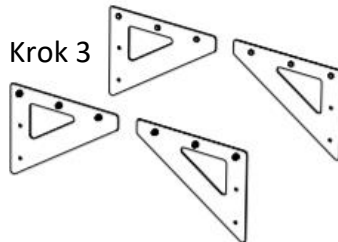

Krok 10

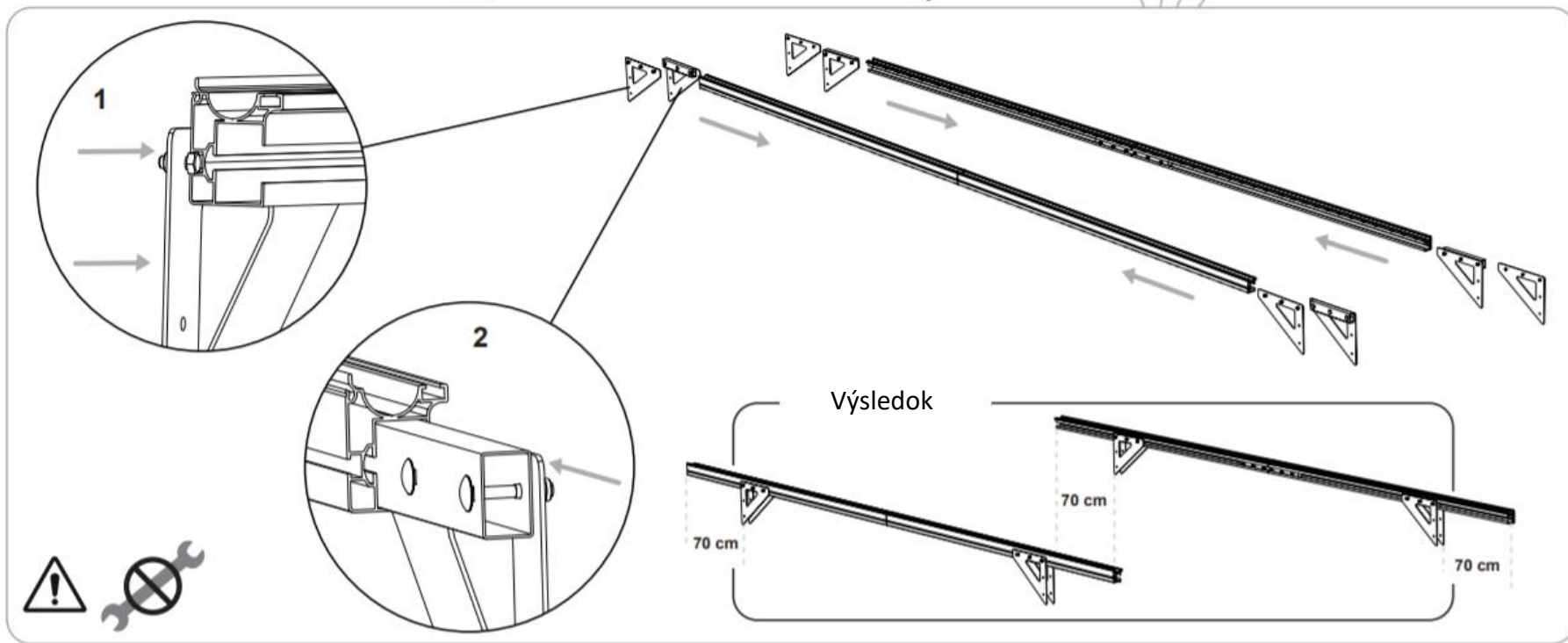

12

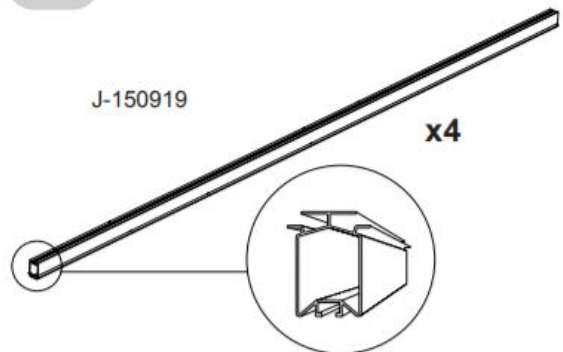

Krok 6

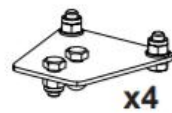

Krok 7

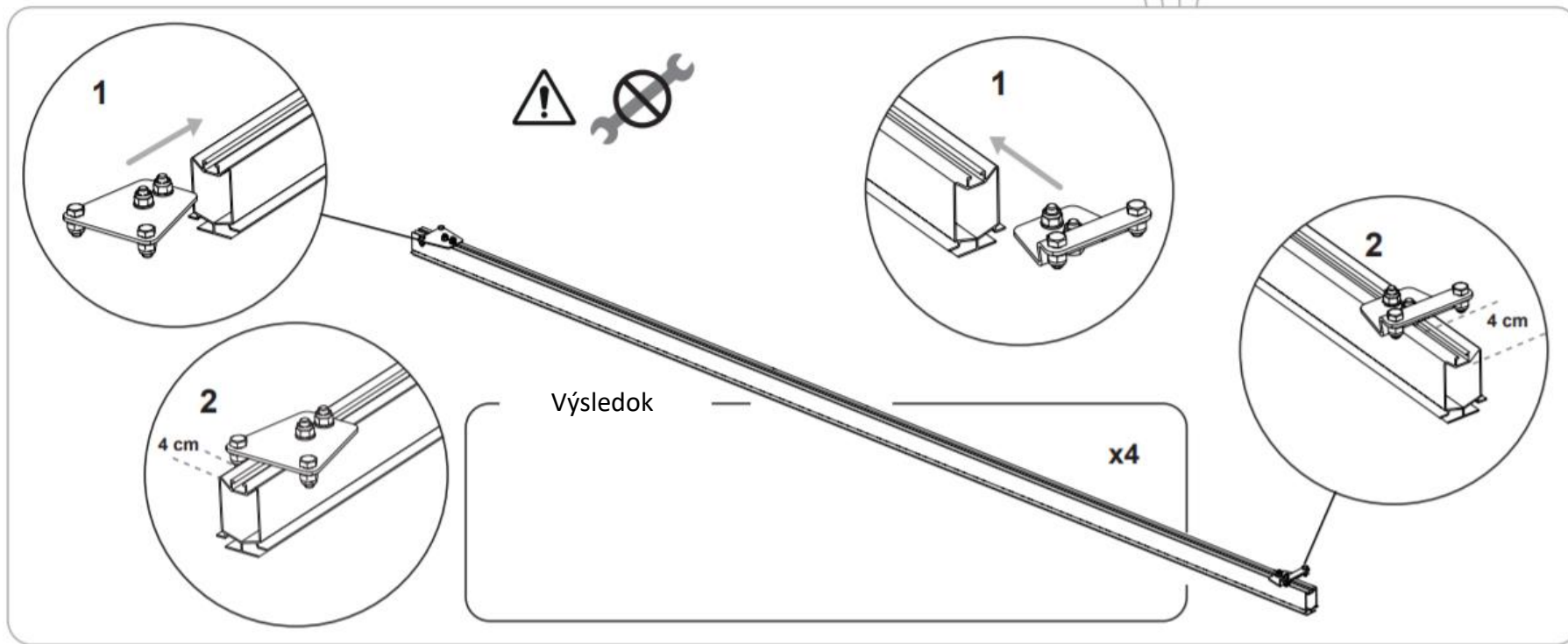
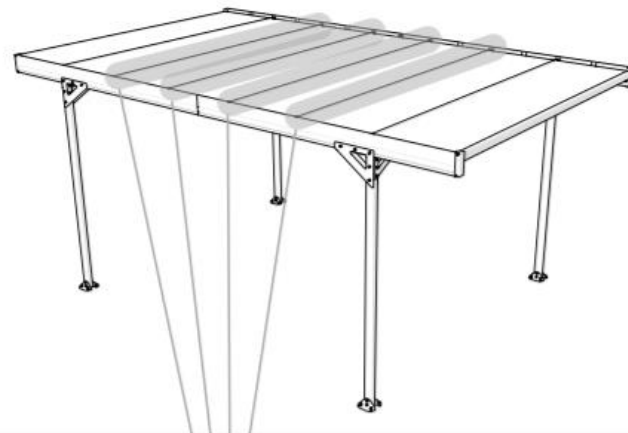

13

J-150920

x2



Krok 8



Krok 9

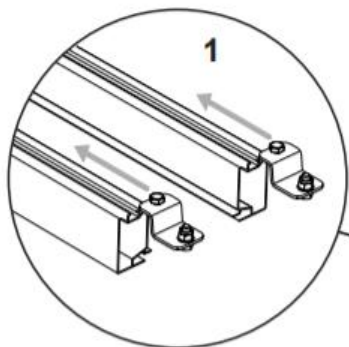
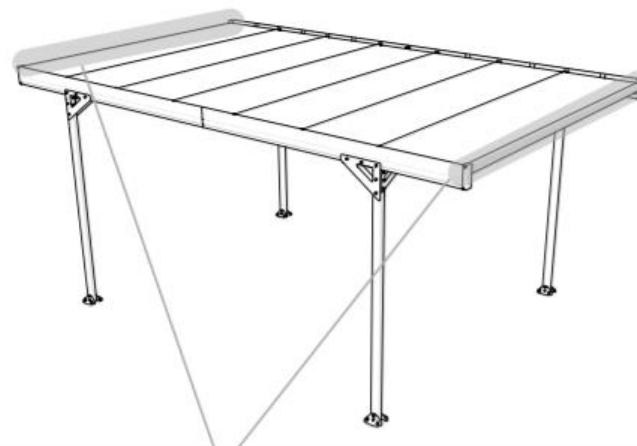

1

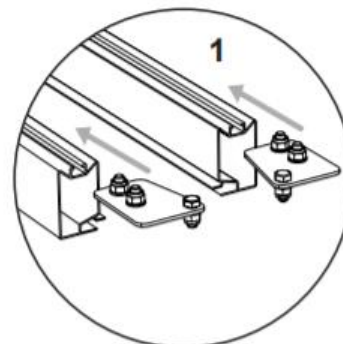

1

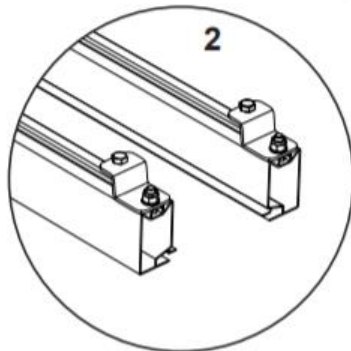

2

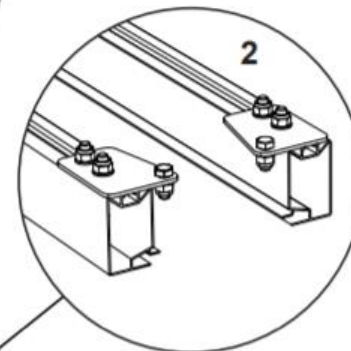

2

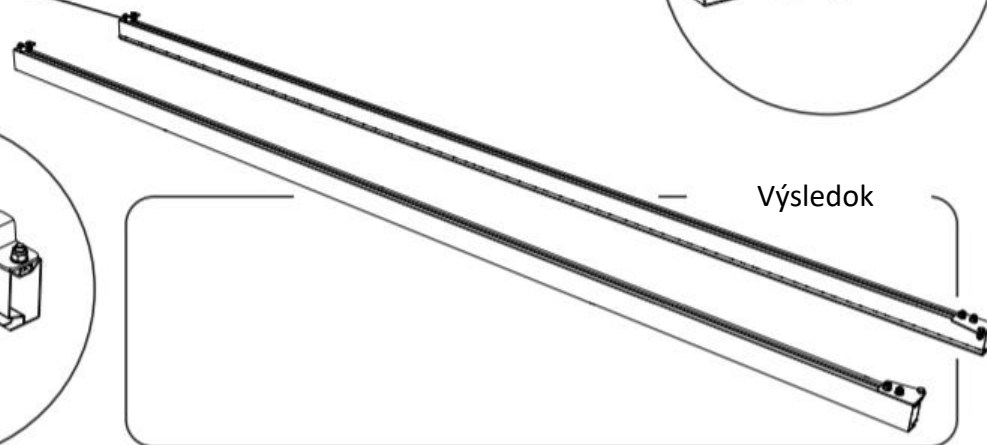

Výsledek

14

J-150919

x2

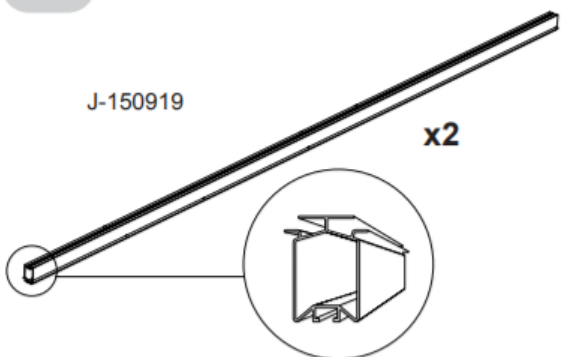

Krok 4

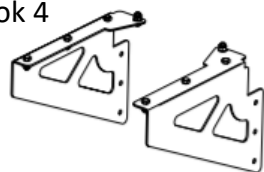

Krok 5

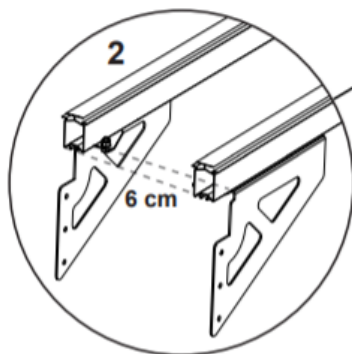
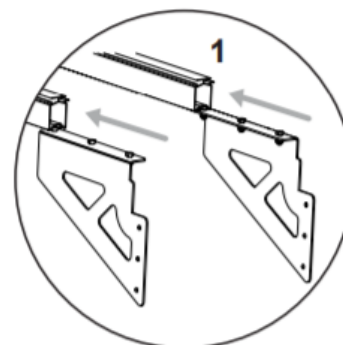
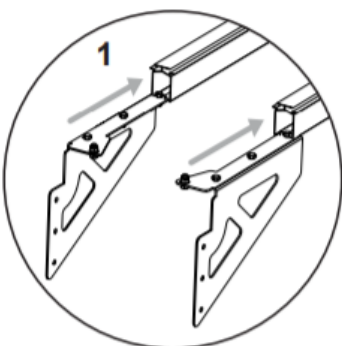
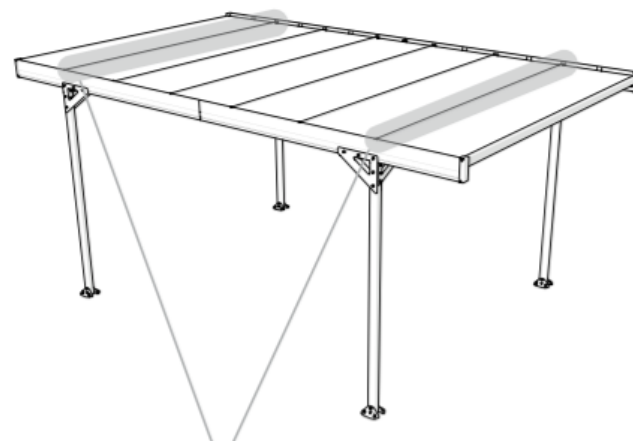
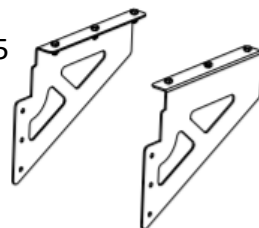

Výsledek

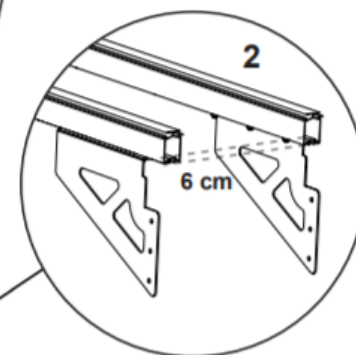
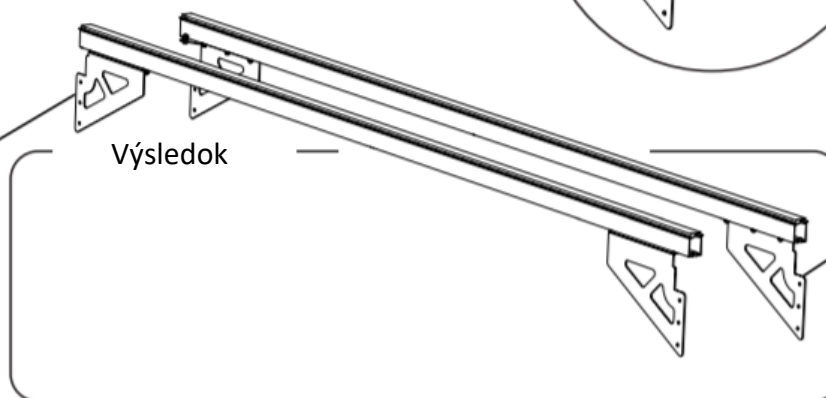

15

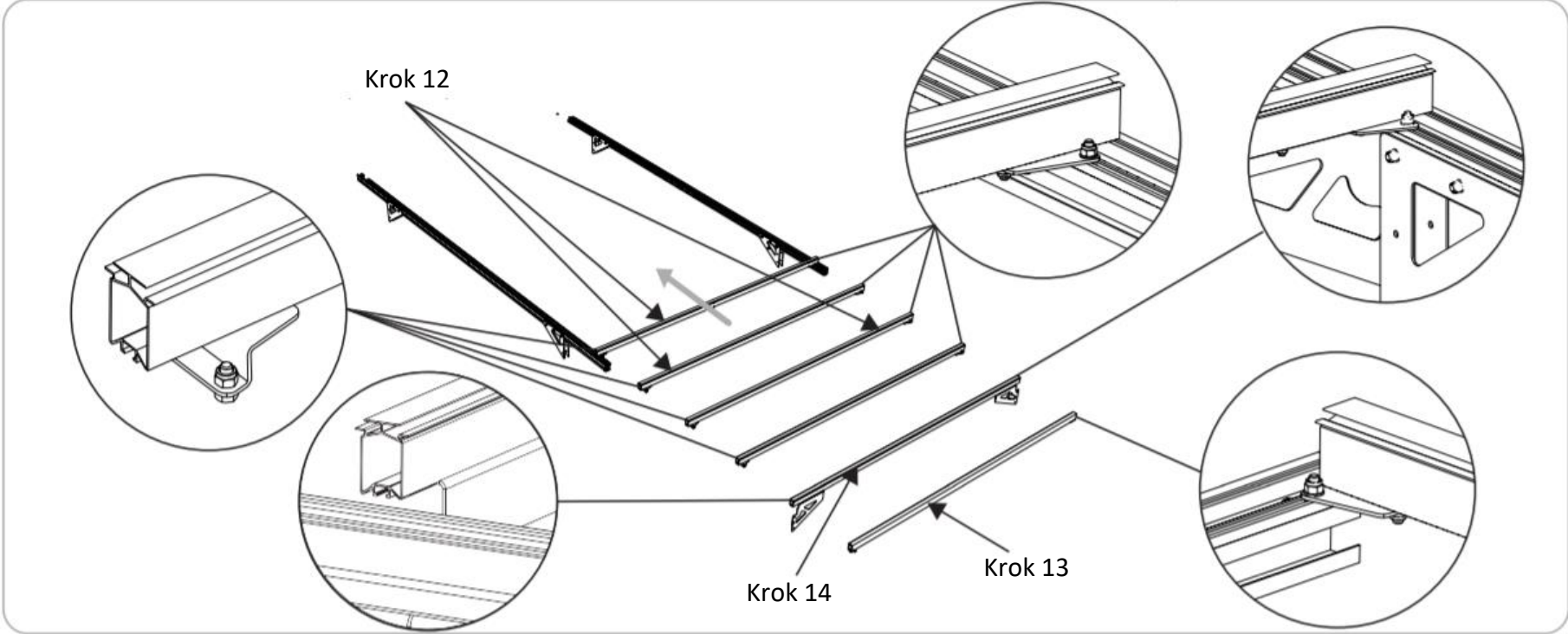
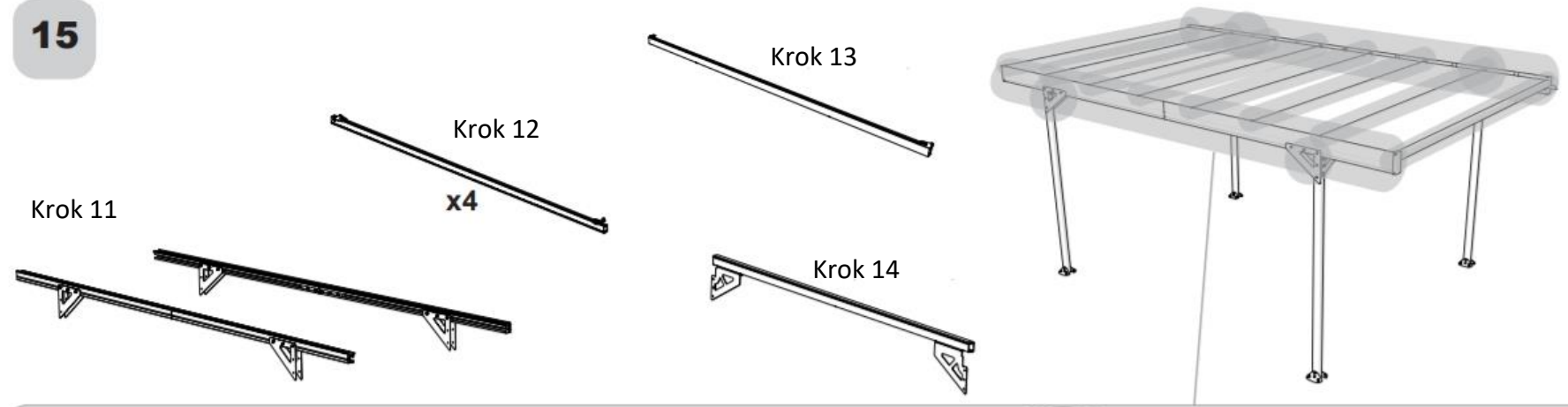

16



Výsledek

65 cm

65 cm

65 cm

65 cm

65 cm

65 cm

65 cm

65 cm

65 cm

65 cm

65 cm

65 cm

!

13

17

J-150930



x7

J-121341



x12

J-121616 Ø5



x12

J-150922

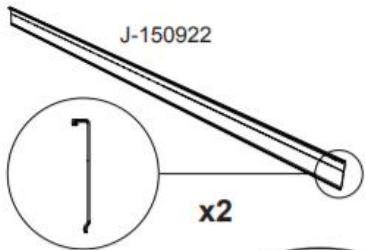

x2



2

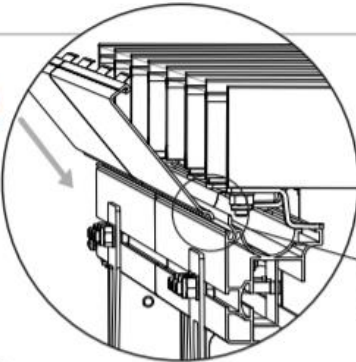

3

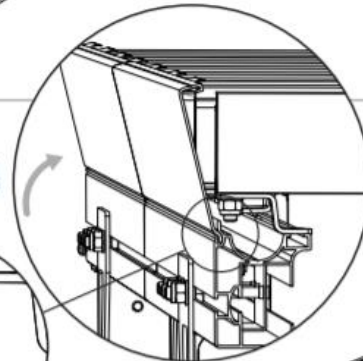

4

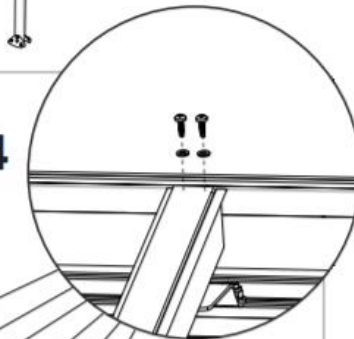

1

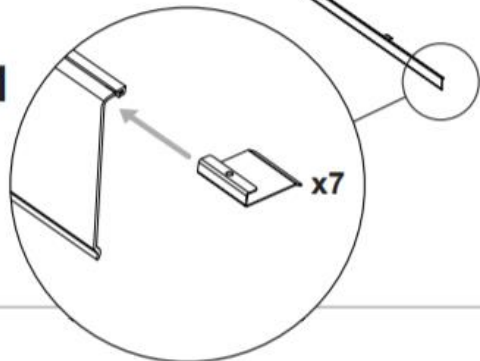

x7

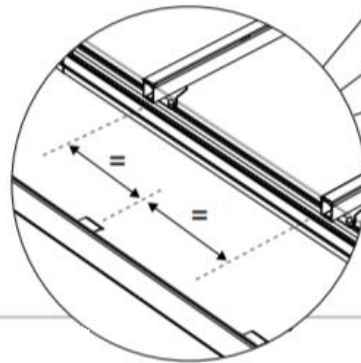

Výsledok

18

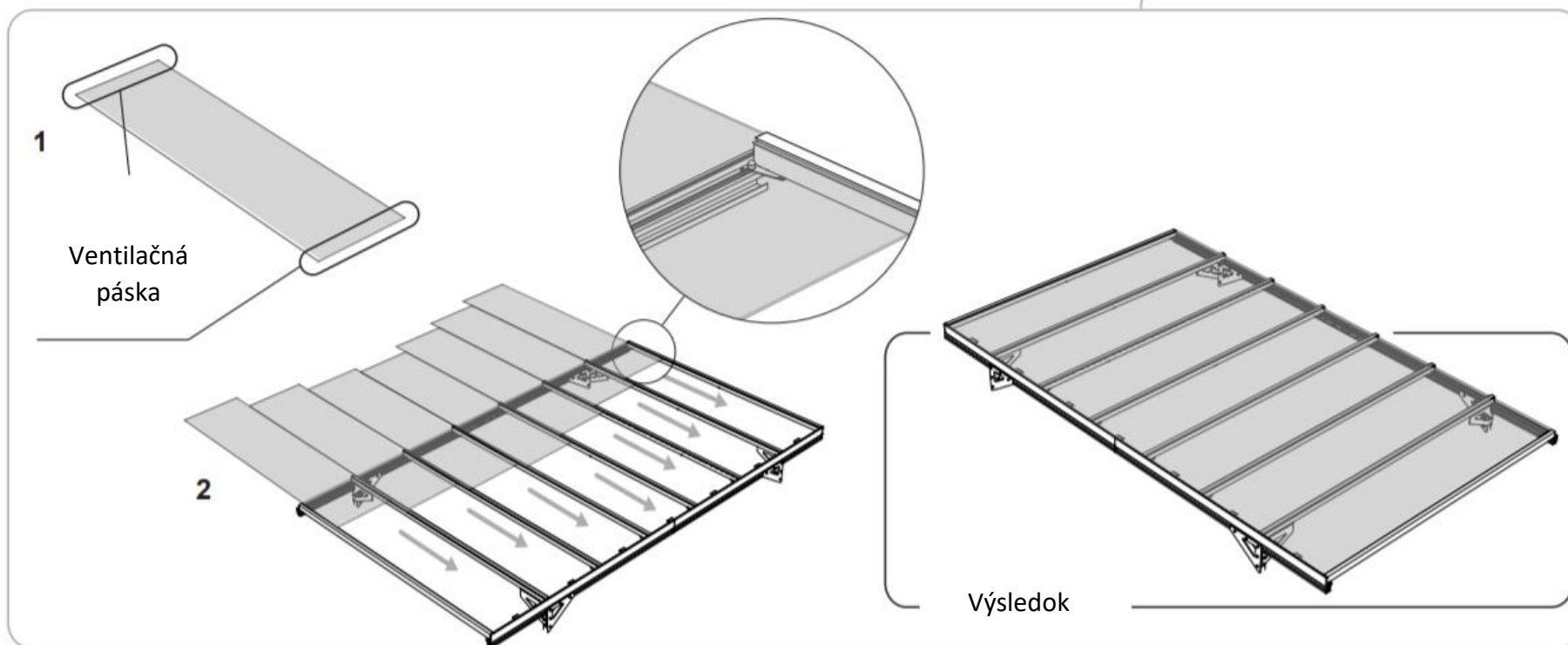
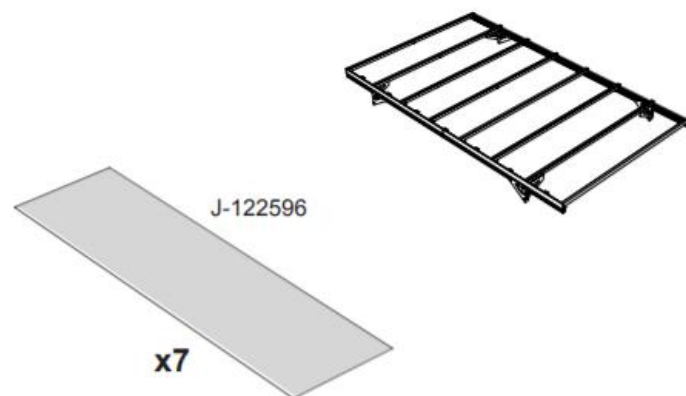

19

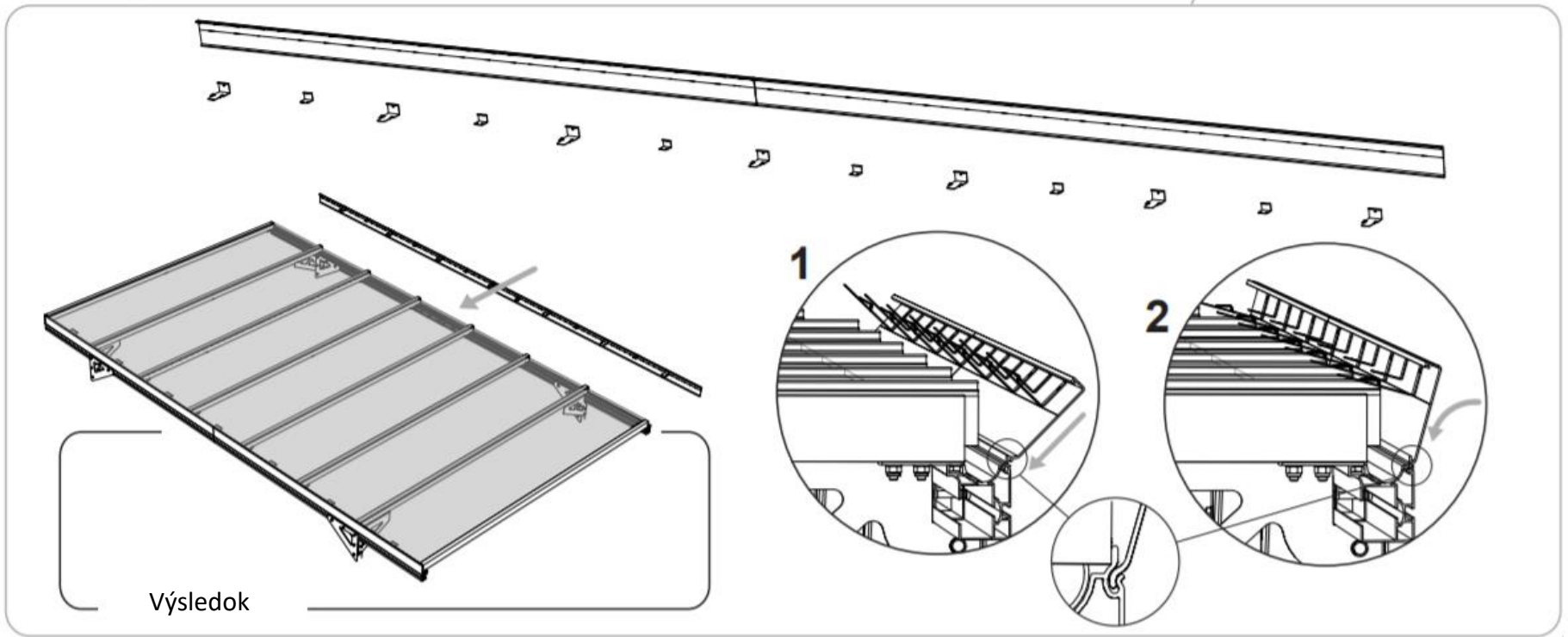
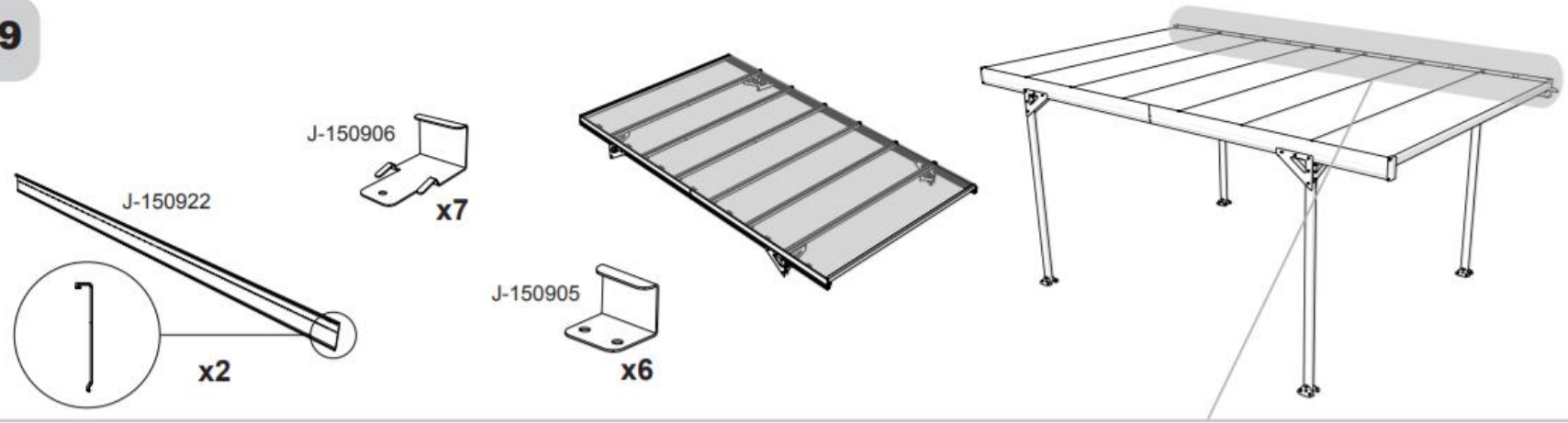

20

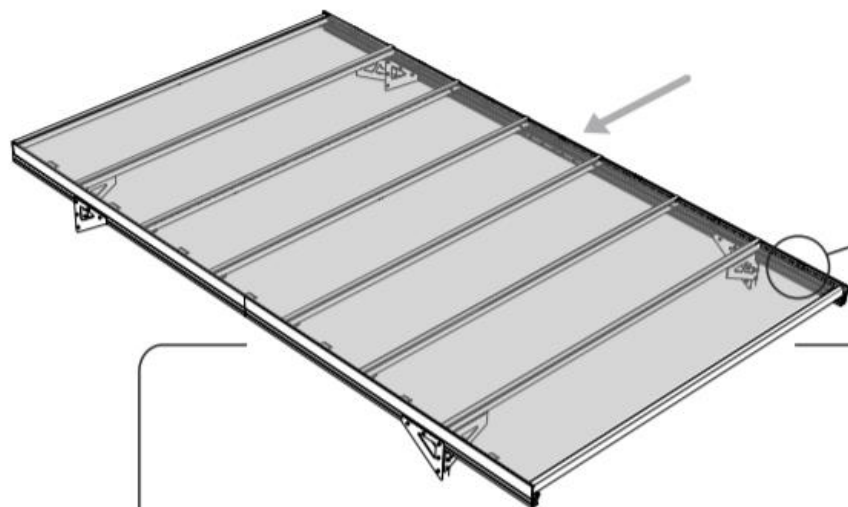
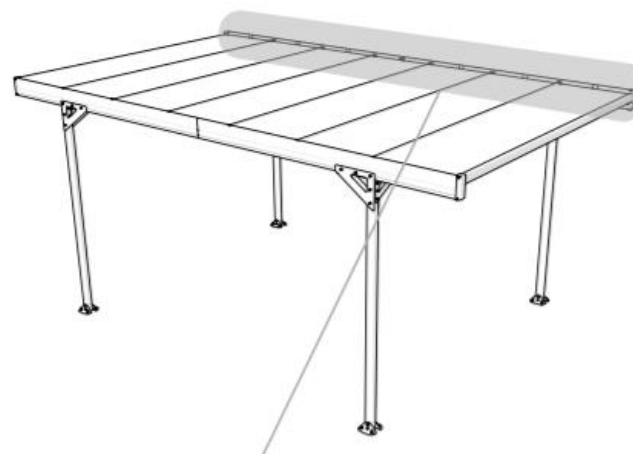

Výsledok

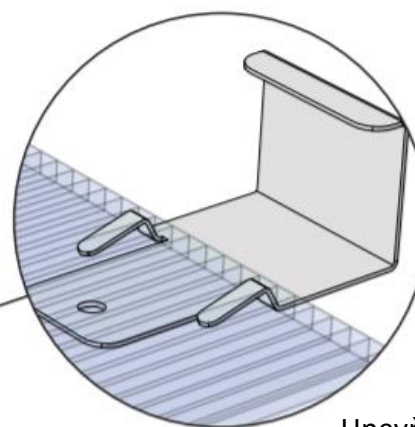

Upevňovacie podpery sa zasúvajú medzi spojovacie rebriny.

21

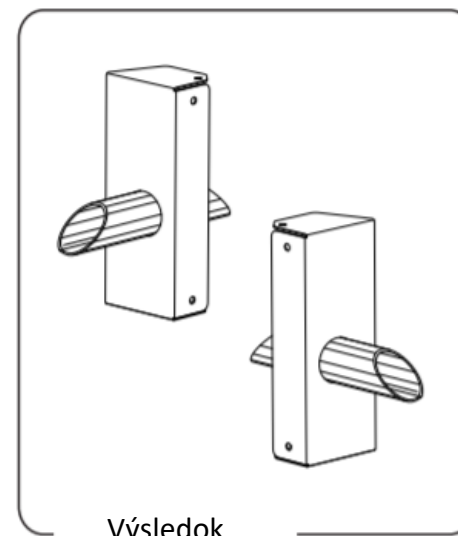
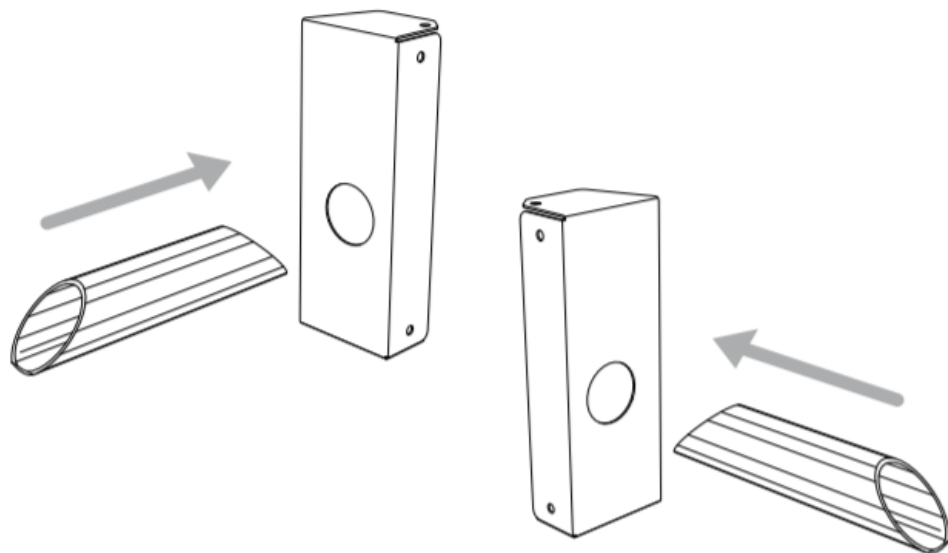
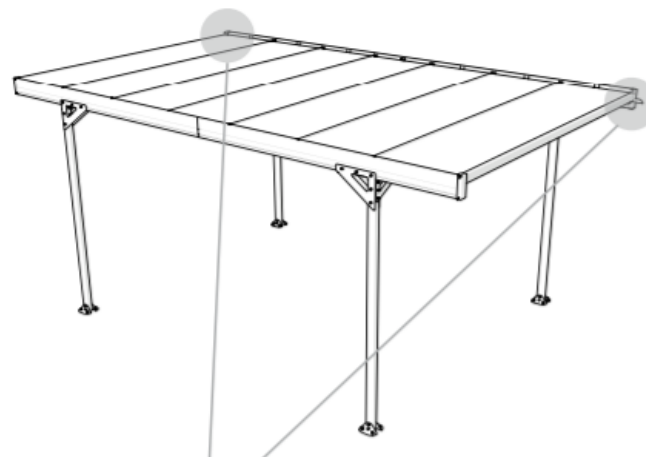
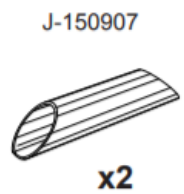

22



J-150916



x2

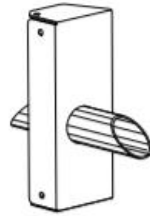
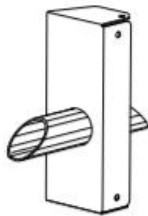

J-121341



x30

J-121616 Ø5



x30

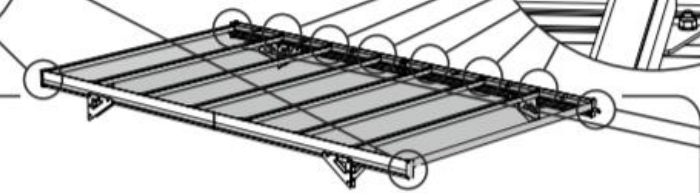
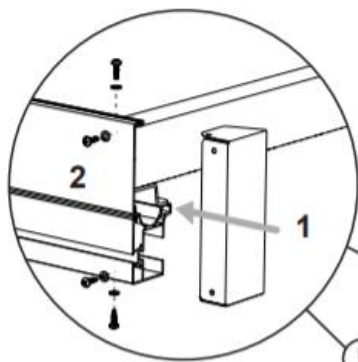
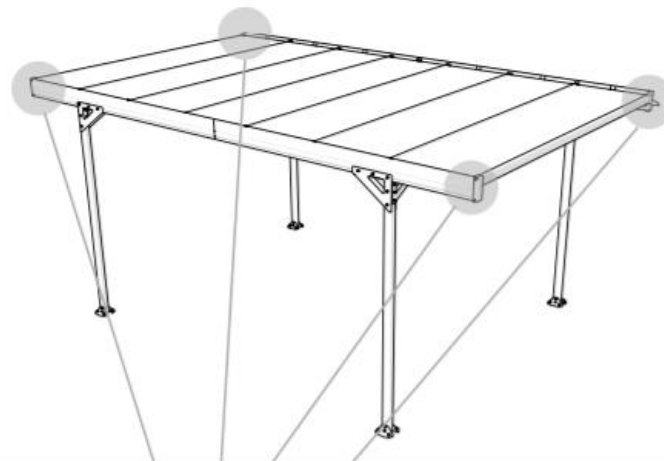

Výsledek

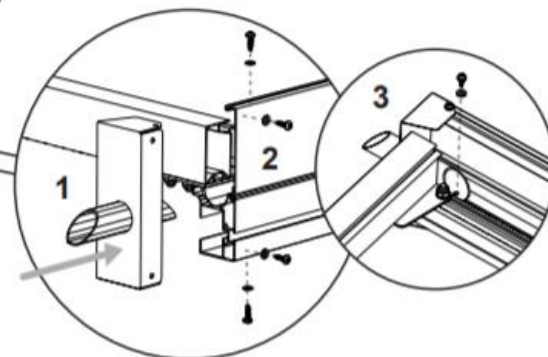

23

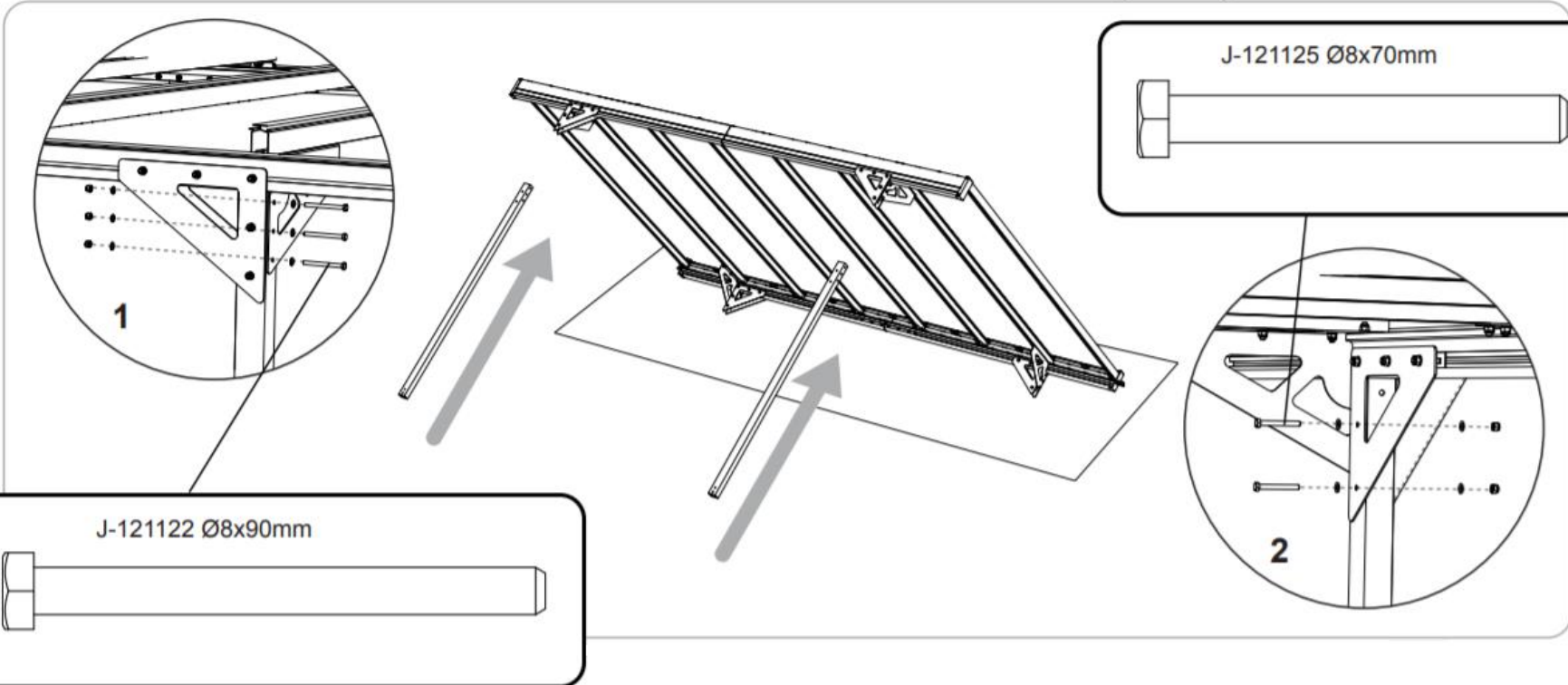
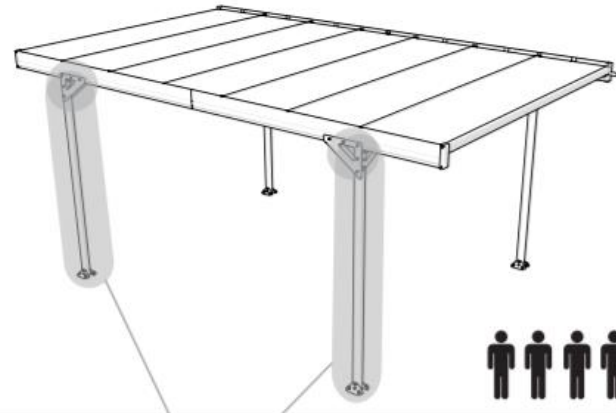
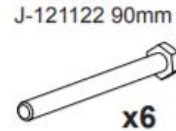
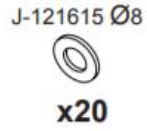
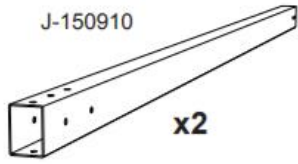

24

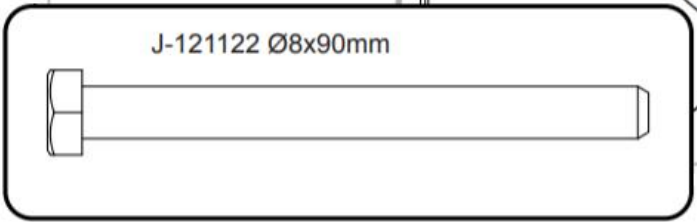
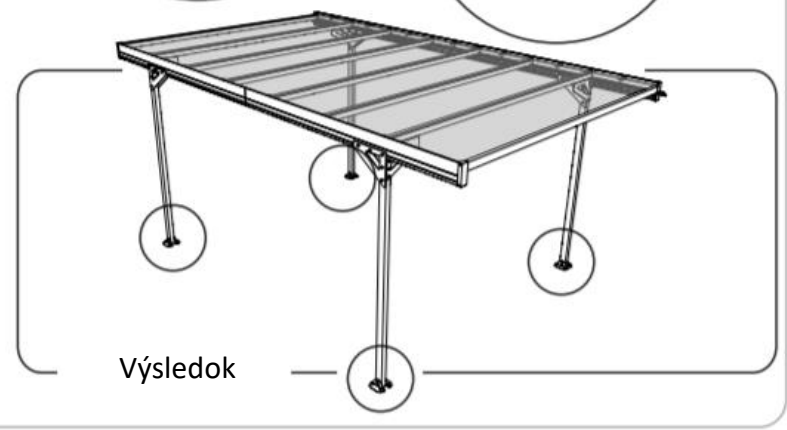
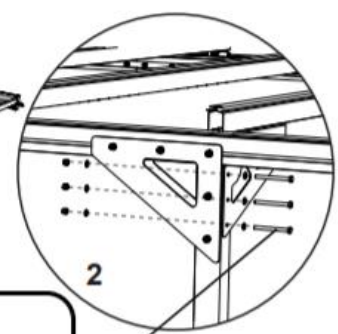
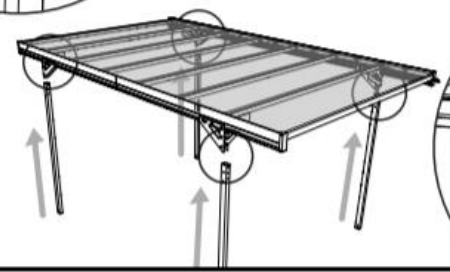
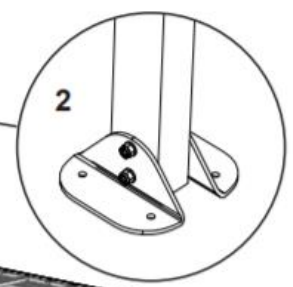
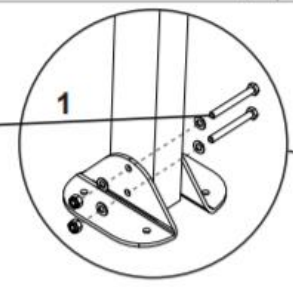
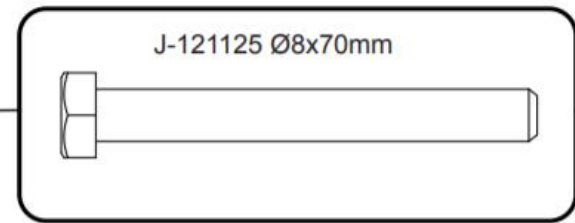
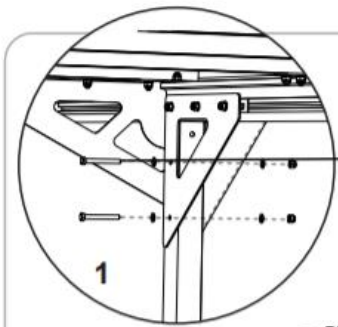
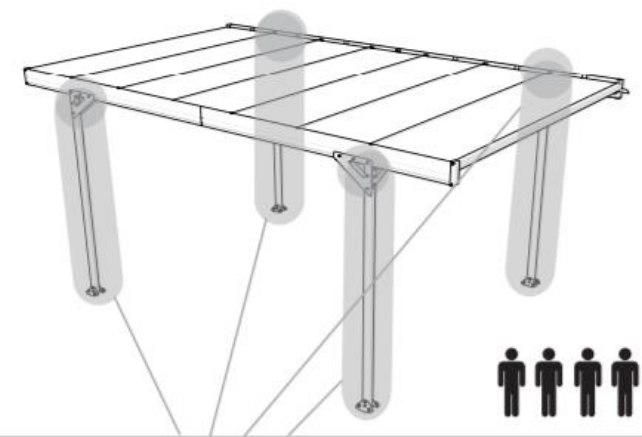
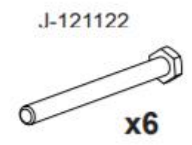
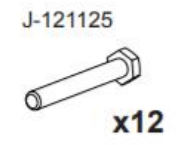
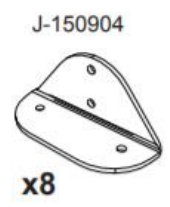
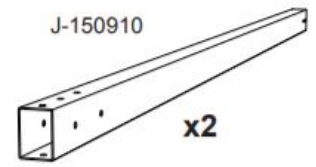

Ukotvenie

J-121374



x16

Ø8 vrták do betónu

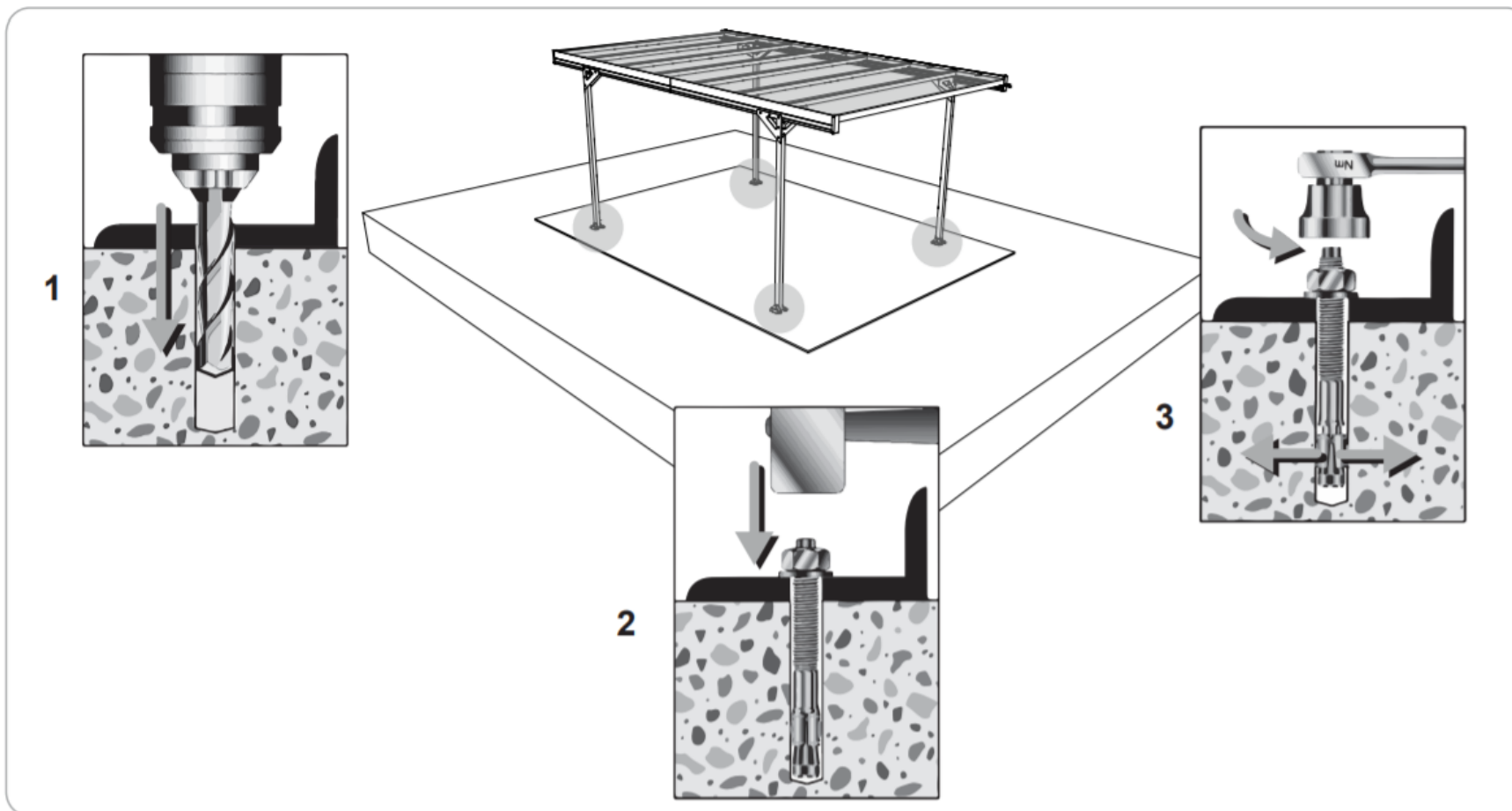

25

J-122594



x164

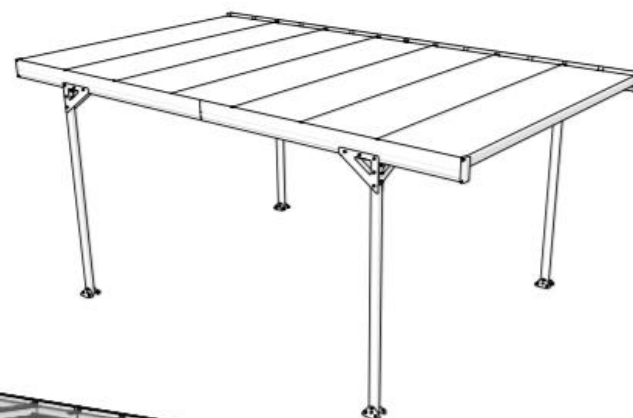

Na všetky matice
pripevnite kryty
matic.

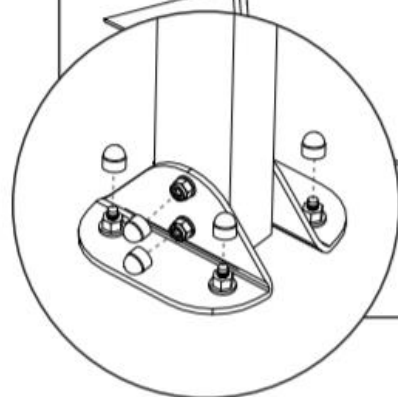

Výsledok